



Technical Data
Specifications & Capacities

TRX80

Translation of the original instructions

[m] [kg]

08.06.2026 | REV0.1

CE
EN 13000:2014

INDEX

Index	2
Crane configuration	3
Overall dimensions	4
Overall informations.....	5
Winch	8
Hookblock.....	9
Winch rope maximum reach.....	10
Driving conditions	11
Turning Radius	12
Stability areas.....	13
Tipping line - Load chart selection.....	14
Stability examples	15
Main boom load chart.....	18
Main boom load tables	19
JIB3502GX load chart.....	21
JIB3502GX load tables.....	22
JIB1502.3HX load chart.....	24
JIB1502.3HX load tables.....	26
JIB1502.3HX features	29
JIB3502GX features	30
Symbols	31

CRANE CONFIGURATION

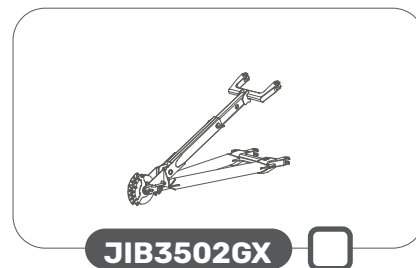
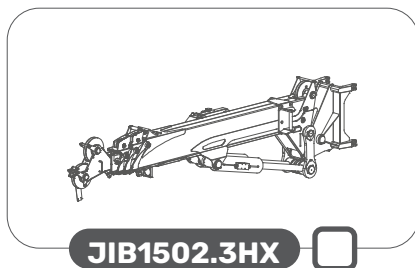
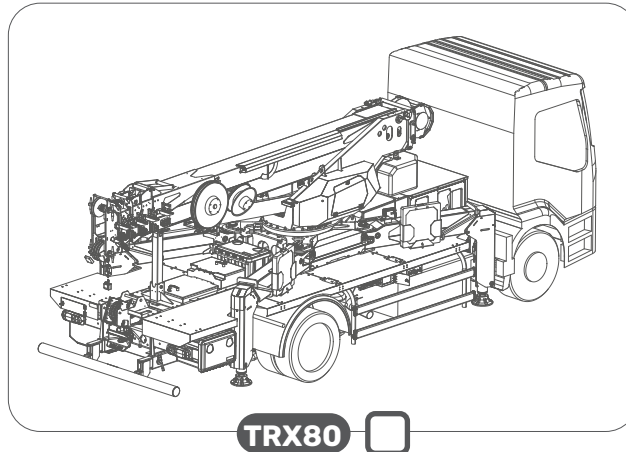

TRX80

Overall dimensions

08.06.2026 | REV0.1

OVERALL DIMENSIONS

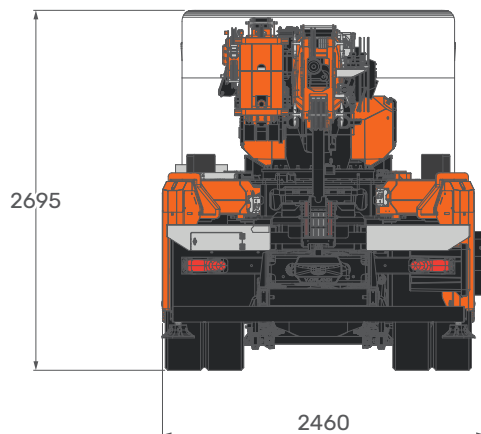
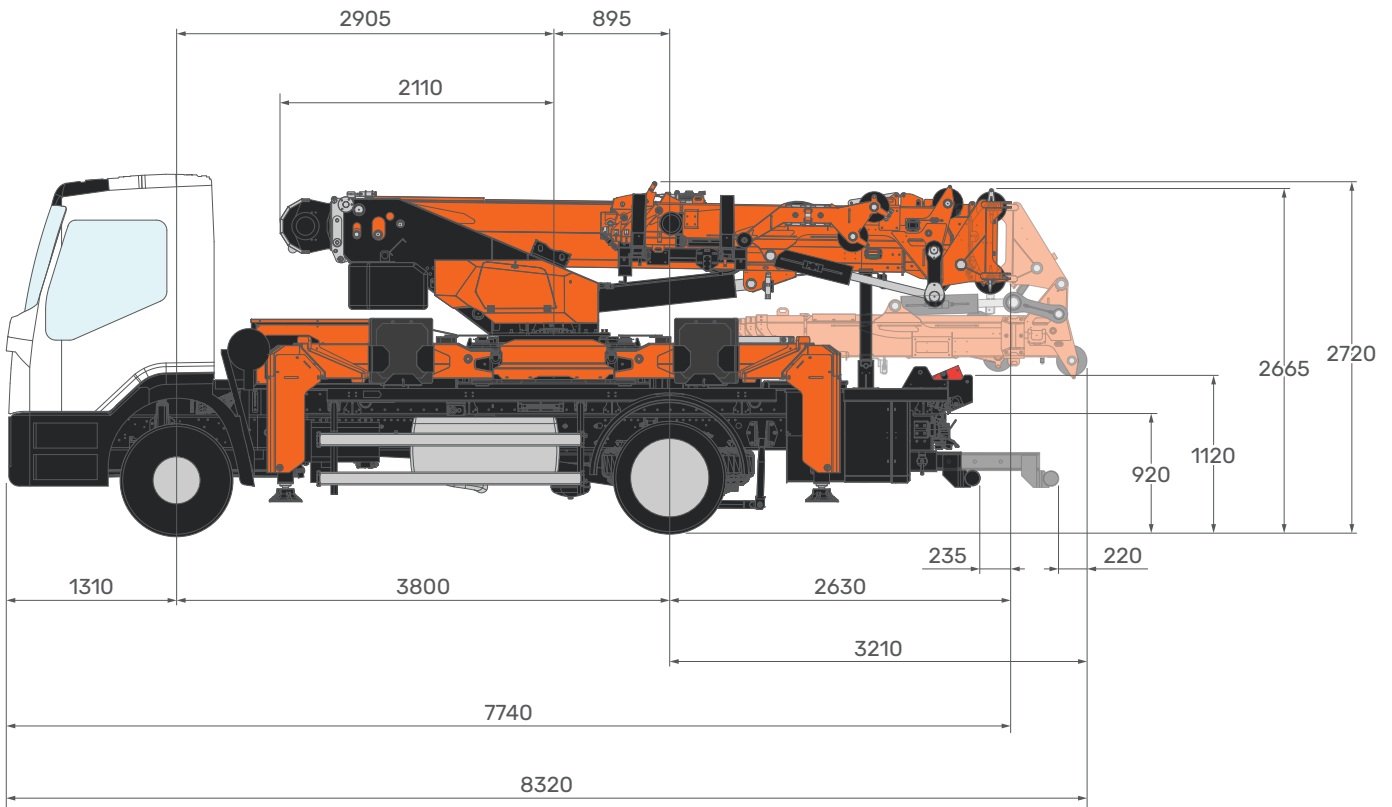

[mm]

OVERALL INFORMATIONS

CRANE INFO



	DESCRIPTION	U.M.	VALUE
OVERALL DIMENSIONS	Height	mm	2.695
	Length		7.740
	Width		2.460
BOOM	Length	m	4,9/17,7
	Speed	s	58 (4,9/17,7 m)
SLEWING	Angle	°	360°
	Speed	rpm	0,8
LIFTING	Working Angle	°	0°/85°
	Speed	s	41 (0°/60°)
MAX CAPACITY		kg	8.000
MAX OUTRIGGERS LOAD	Closed	kg	8.000 ^[1]
	Extended		11.100 ^[1]
WORKING TEMPERATURE		°C	-10°/+40°
MAX WIND SPEED IN WORKING CONDITIONS		m/s	13,8
Lifting Class (UNI 4301-1)		A1	

^[1]: Static lifting

TRX80

Overall informations

08.06.2026 | REV0.1

WEIGHT



TRUCK	DAF XB 16 TON 4x2		kg	4.675
CRANE INSTALLATION	Standard Configuration	With Counterweight	kg	7.975 ^{[1][2][3]}
TOTAL	TRX80		kg	12.650 ^{[1][2][3]}

ACCESSORIES



HOOKBLOCK	2 ton single line hook	kg	42
	3.2T-D10		35
	8.5T-D10		109
JIB	3502GX	kg	70
	1502.3HX		675
HYDRAULIC ACTIVATION	HA-SPX1280	kg	40
	HA-JIB1502.3HX		20
OUTRIGGERS MATS	OM500.1 (x4)	kg	92

^[1]: Dry weight

^[2]: Estimated fluids weight = 290 kg

^[3]: Without operators (75 kg each)

MOTOR		MOTORIZATION	Power Supply	Lithium Battery	
			Battery Tension	V	48
			Battery Capacity	Ah	610
			Motor Power	kW	12

ELECTRIC SYSTEM		POWER SUPPLY	CE	1 PH + N + PE			
				3 PH + N + PE			
BATTERY CHARGER		BATTERY CHARGER	CE	1 PH + N + PE	Charge	V	48
						Ah	50
				3 PH + N + PE	Charge	V	48
						Ah	140

HYDRAULIC SYSTEM		MAX WORKING PRESSURE		bar	230	
		TANK CAPACITY		L	100	
		HYDRAULIC SYSTEM CAPACITY		L	180	
		OIL	OIL-1280		Biodegradable	ISO VG46
			ARTIC-OIL-1280		Mineral	ISO VG46
		PUMP	Displacement		cm ³ /rev	28
Max Oil Flow			L/min	80		

WINCH

WINCH



LAYER	MAX PULL LINE kg	ROPE SPEED	
		SLOW m/min	FAST m/min
1	2.072 ^[1]	46,4	83,5
2	1.893 ^[1]	50,7	91,4
3	1.743 ^[1]	55,1	99,3
4	1.615 ^[1]	59,5	107,2
5	1.504 ^[1]	63,8	115,1

ROPE

WIRE ROPE	BREAKING LOAD kg	∅ mm	TOTAL LENGTH m
Anti-twist 19x7 right lang lay	9.480	10	125

^[1]: LMI limited at 1500 kg.

Maximum speed and maximum lifting capacity cannot be contemporary.

HOOKBLOCK

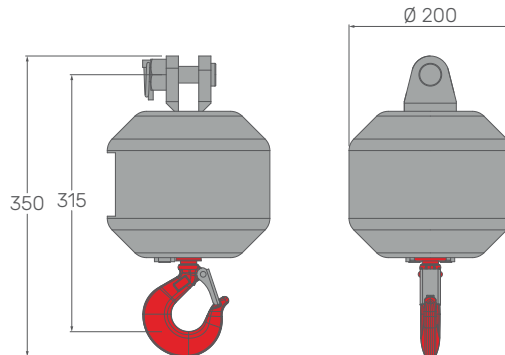

MODEL	LOAD		N° OF	
			Sheaves	Lines
2 ton single line hook	kg	1.500	-	1

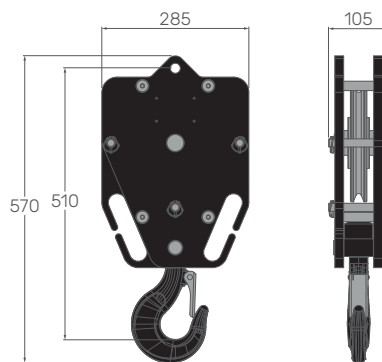

MODEL	LOAD		N° OF	
			Sheaves	Lines
3.2T-D10	kg	3.000	1	2

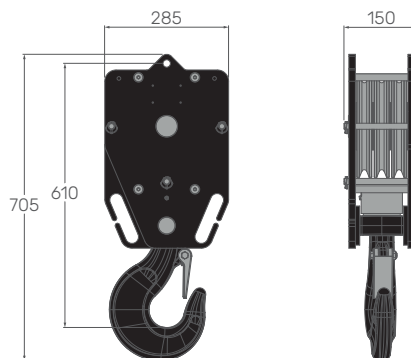

MODEL	LOAD		N° OF	
			Sheaves	Lines
8.5T-D10	kg	3.000	3	2
		6.000		4
		8.000		6

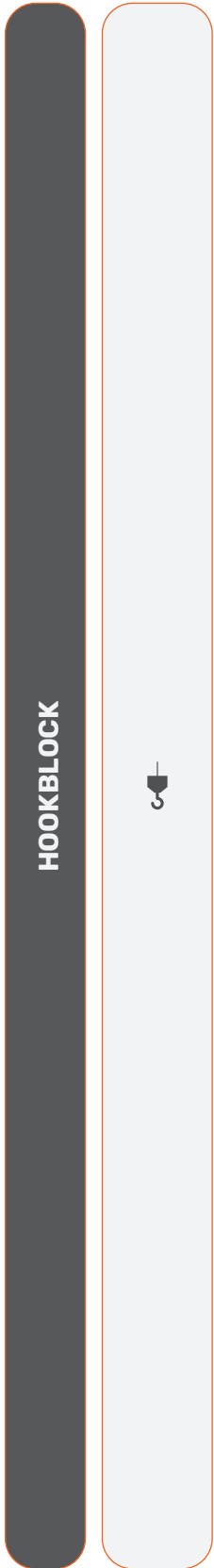

TRX80

Winch rope maximum reach

08.06.2026 | REV0.1

WINCH ROPE MAX REACH

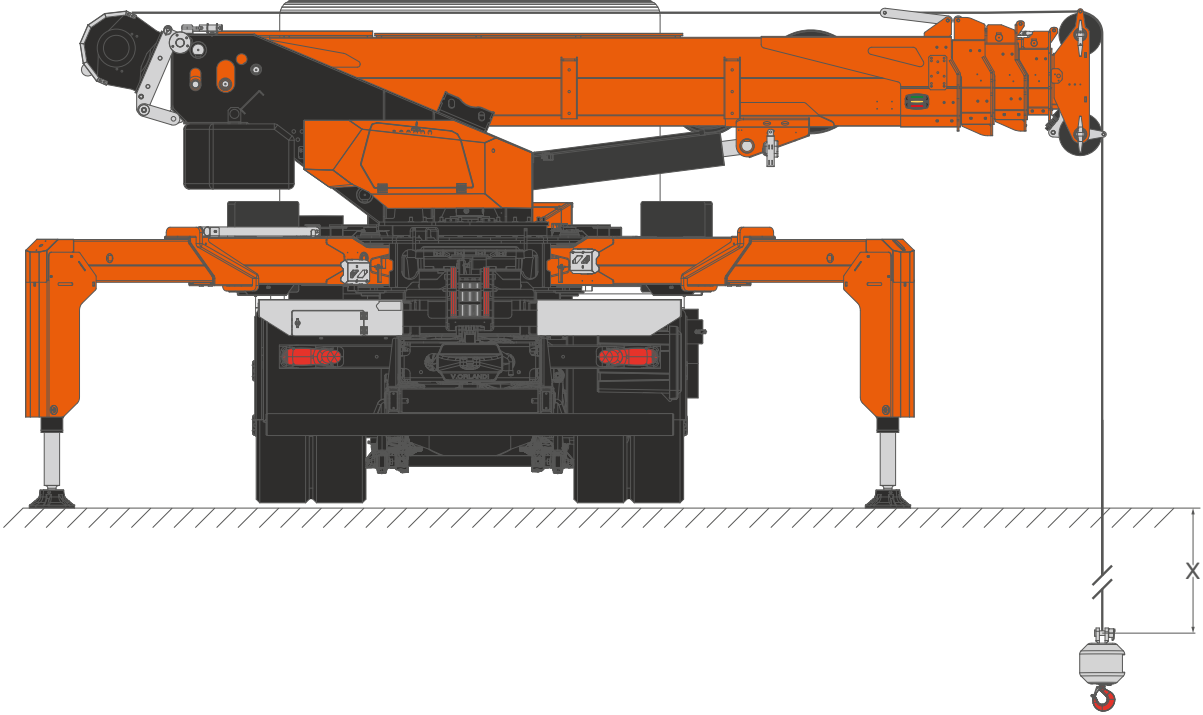

ROPE		WINCH	Parts of Line	1	m	112
				2		54
				4		25
				6		16

DRIVING CONDITIONS

AXLE LOAD

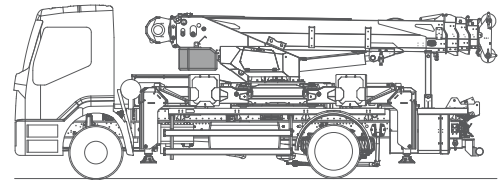
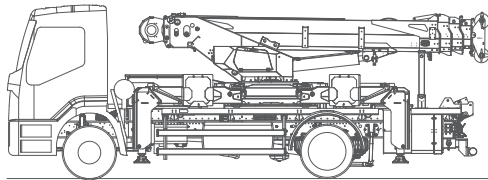

CONFIGURATION	FRONT	REAR	TOTAL
	kg		
WITHOUT COUNTERWEIGHT	4.230 ^[1]	7.710 ^[1]	11.940
WITH COUNTERWEIGHT	5.130 ^[1]	8.310 ^[1]	13.440

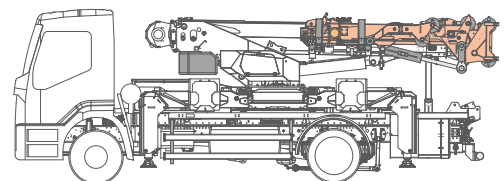
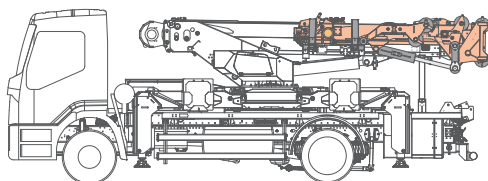

CONFIGURATION	FRONT	REAR	TOTAL
	kg		
WITHOUT COUNTERWEIGHT	4.040 ^[1]	8.580 ^[1]	12.620
WITH COUNTERWEIGHT	4.940 ^[1]	9.170 ^[1]	14.110

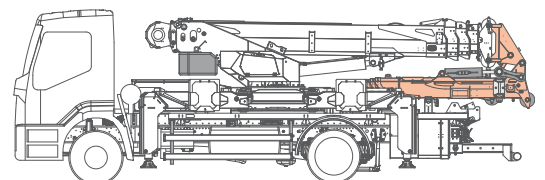
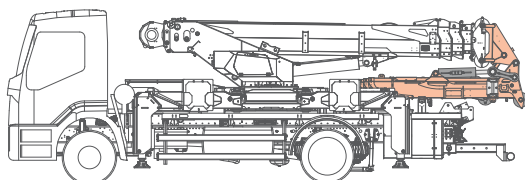

CONFIGURATION	FRONT	REAR	TOTAL
	kg		
WITHOUT COUNTERWEIGHT	3.940 ^[1]	8.680 ^[1]	12.620
WITH COUNTERWEIGHT	4.840 ^[1]	9.270 ^[1]	14.110

^[1]: The indicated loads consider two persons on board, all operating fluids and accessories

^[2]: Max vehicle load: Front 6.000 kg - Rear 10.500 kg

TRX80

Turning Radius

08.06.2026 | REV0.1

TURNING RADIUS

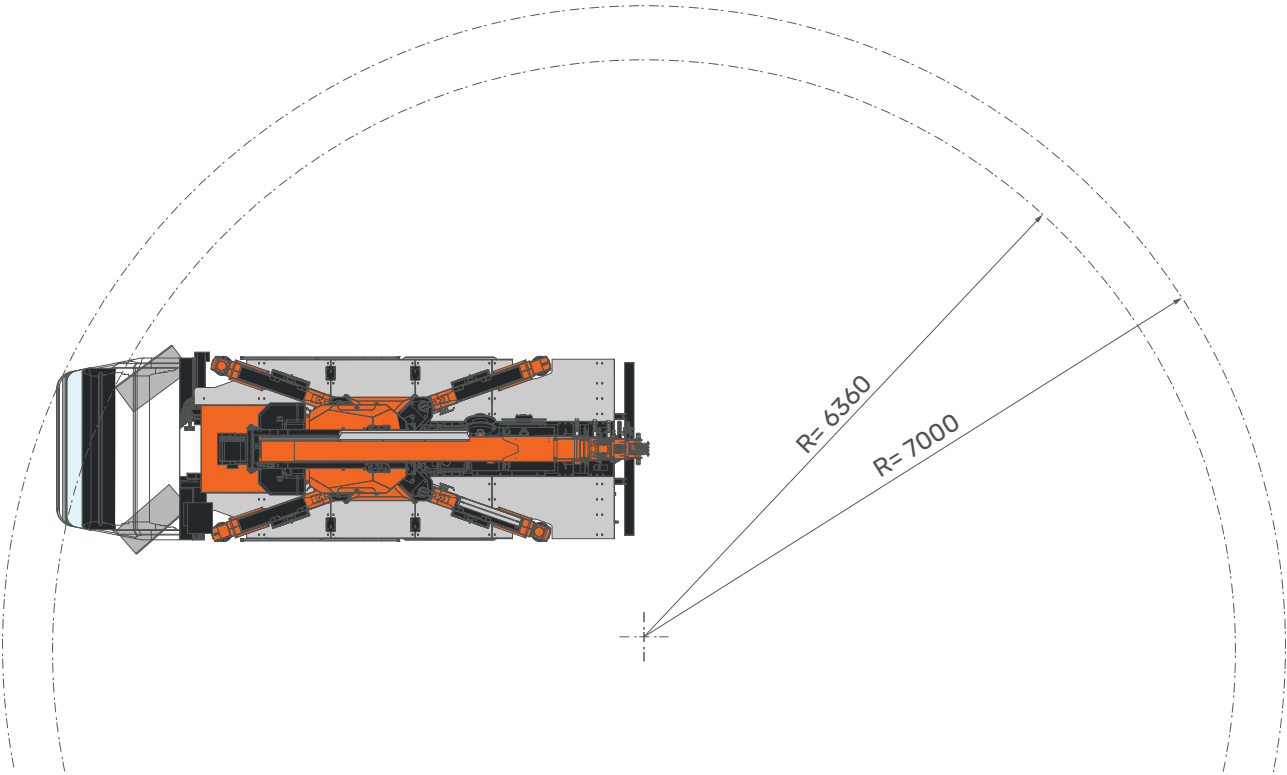

STABILITY AREAS

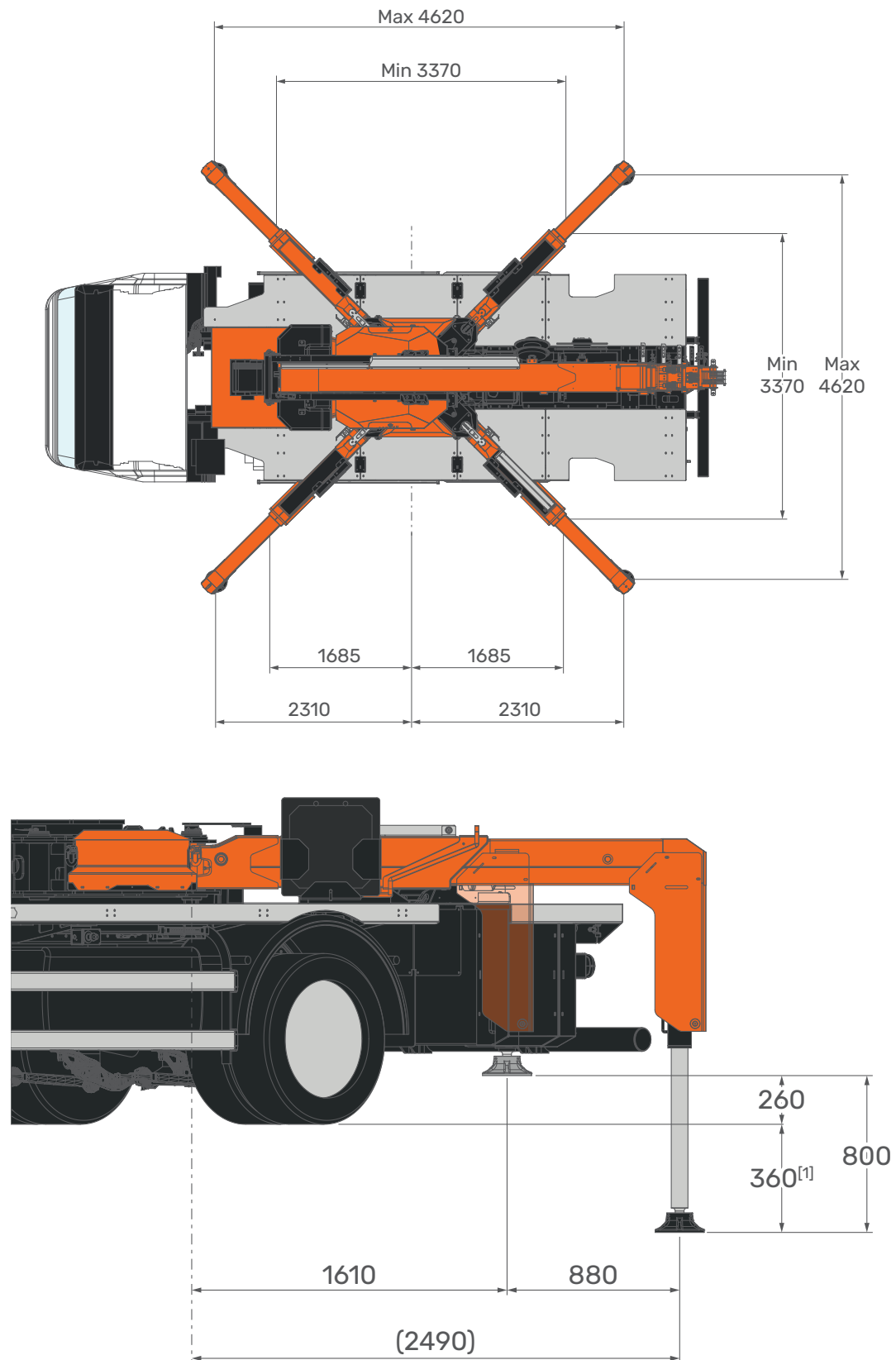

[mm] ^[1]: The dimension has been given considering the suspension travel

TRX80

Tipping line - Load chart selection

08.06.2026 | REV0.1

TIPPING LINE

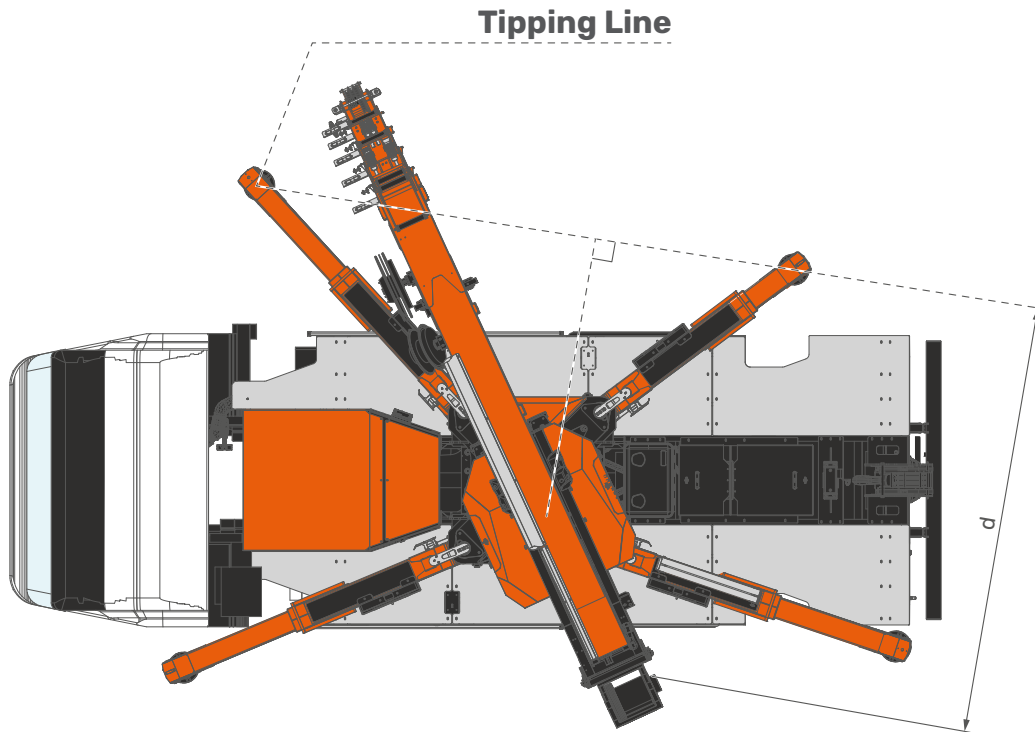

LOAD CHART SELECTION

LOAD CHART	d = 1,04 m		d = 1,34 m		d = 1,68 m		d = 2,0 m	
								J7
						J6		
				J5				
			J4					
J0 - No LIFTING CAPACITY								

STABILITY AREA

LOAD CHART	FUNCTION
J4-J7	Crane Stabilized
J0	No Lifting Capacity

CRANE PERFORMANCE

STABILITY EXAMPLES

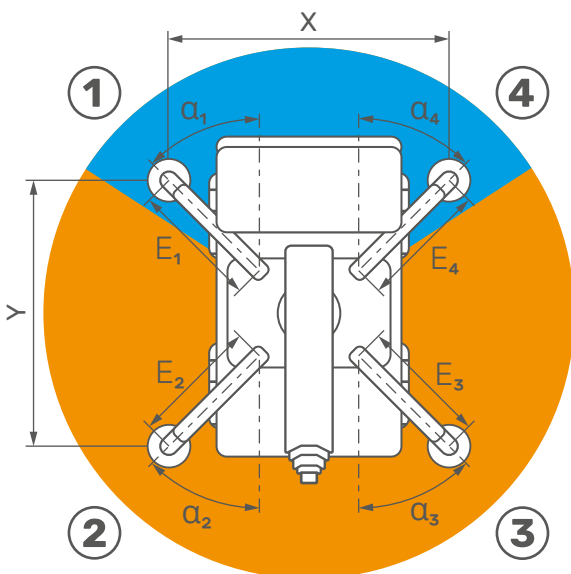
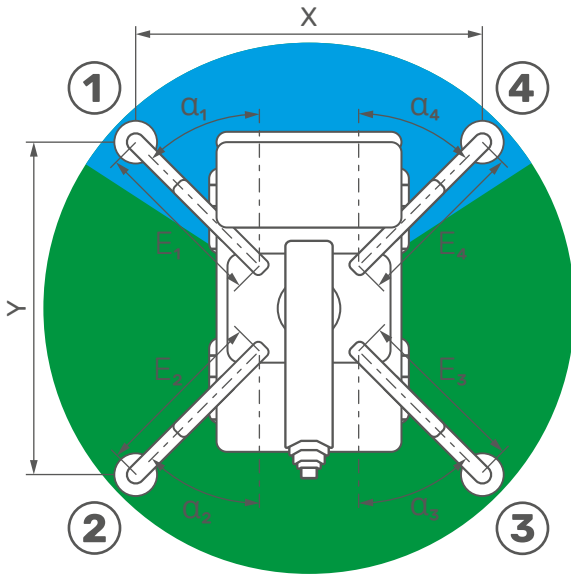

FULLY SYMMETRIC STABILITY

OUTRIGGERS EXTENSION	OUTRIGGERS ANGLE	
	FOOTPRINT DIMENSIONS	
X	4,6 m	
Y	4,6 m	
α_1	45°	
α_2	45°	
α_3	45°	
α_4	45°	
E_1	2,5 m	
E_2	2,5 m	
E_3	2,5 m	
E_4	2,5 m	
J7	250°	
J4	110°	

FULLY SYMMETRIC STABILITY

OUTRIGGERS EXTENSION	OUTRIGGERS ANGLE	
	FOOTPRINT DIMENSIONS	
X	3,3 m	
Y	3,3 m	
α_1	45°	
α_2	45°	
α_3	45°	
α_4	45°	
E_1	1,6 m	
E_2	1,6 m	
E_3	1,6 m	
E_4	1,6 m	
J6	250°	
J4	110°	

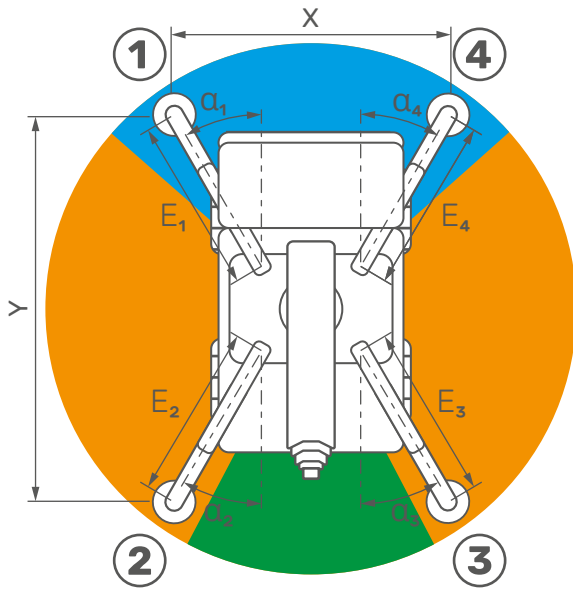

FULLY SYMMETRIC STABILITY

FOOTPRINT DIMENSIONS	X	3,5 m
Y	5,4 m	
OUTRIGGERS ANGLE	α_1	30°
α_2	30°	
α_3	30°	
α_4	30°	
OUTRIGGERS EXTENSION	E_1	2,5 m
E_2	2,5 m	
E_3	2,5 m	
E_4	2,5 m	
J7	47°	
J6	226°	
J4	87°	

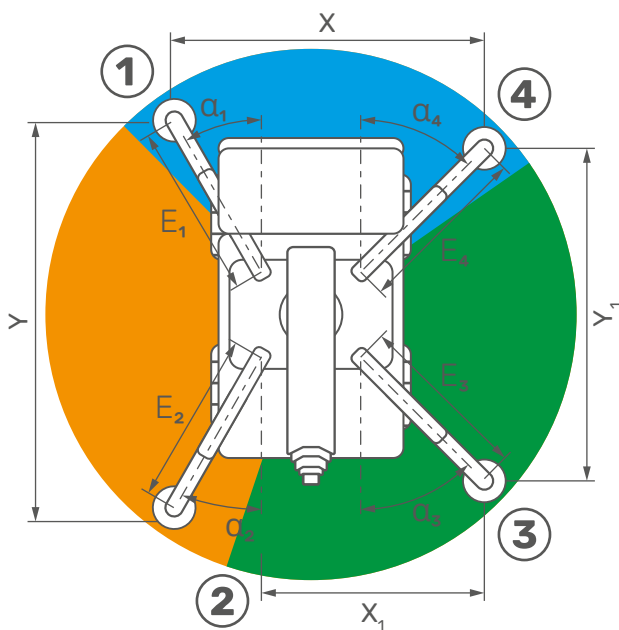

ASYMMETRIC STABILITY

FOOTPRINT DIMENSIONS	X	4,1 m
X_1	4,1 m	
Y	5,4 m	
Y_1	4,6 m	
OUTRIGGERS ANGLE	α_1	30°
α_2	30°	
α_3	45°	
α_4	45°	
OUTRIGGERS EXTENSION	E_1	2,5 m
E_2	2,5 m	
E_3	2,5 m	
E_4	2,5 m	
J7	148°	
J6	113°	
J4	99°	

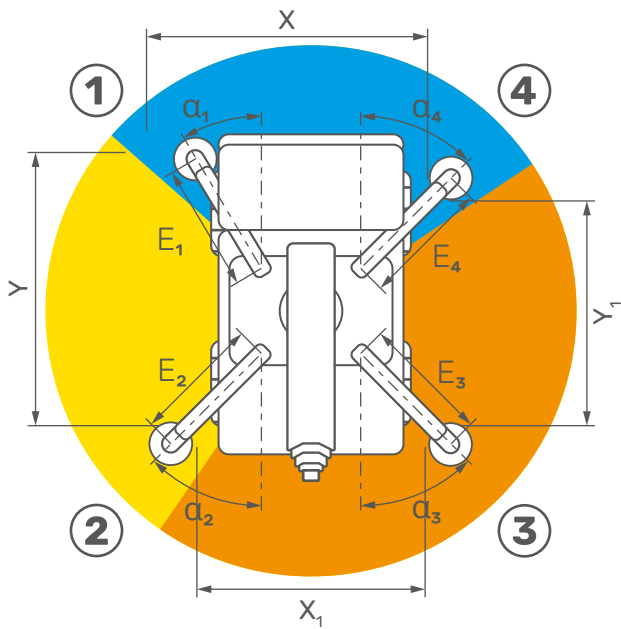

ASYMMETRIC STABILITY

FOOTPRINT DIMENSIONS	X	2,7 m
X ₁	3,3 m	
Y	3,7 m	
Y ₁	3,3 m	
OUTRIGGERS ANGLE	α_1	20°
α_2	45°	
α_3	45°	
α_4	45°	
OUTRIGGERS EXTENSION	E ₁	1,6 m
E ₂	1,6 m	
E ₃	1,6 m	
E ₄	1,6 m	
J5	107°	
J4	93°	
J6	160°	

TRX80

Main boom load chart

08.06.2026 | REV.01

MAIN BOOM

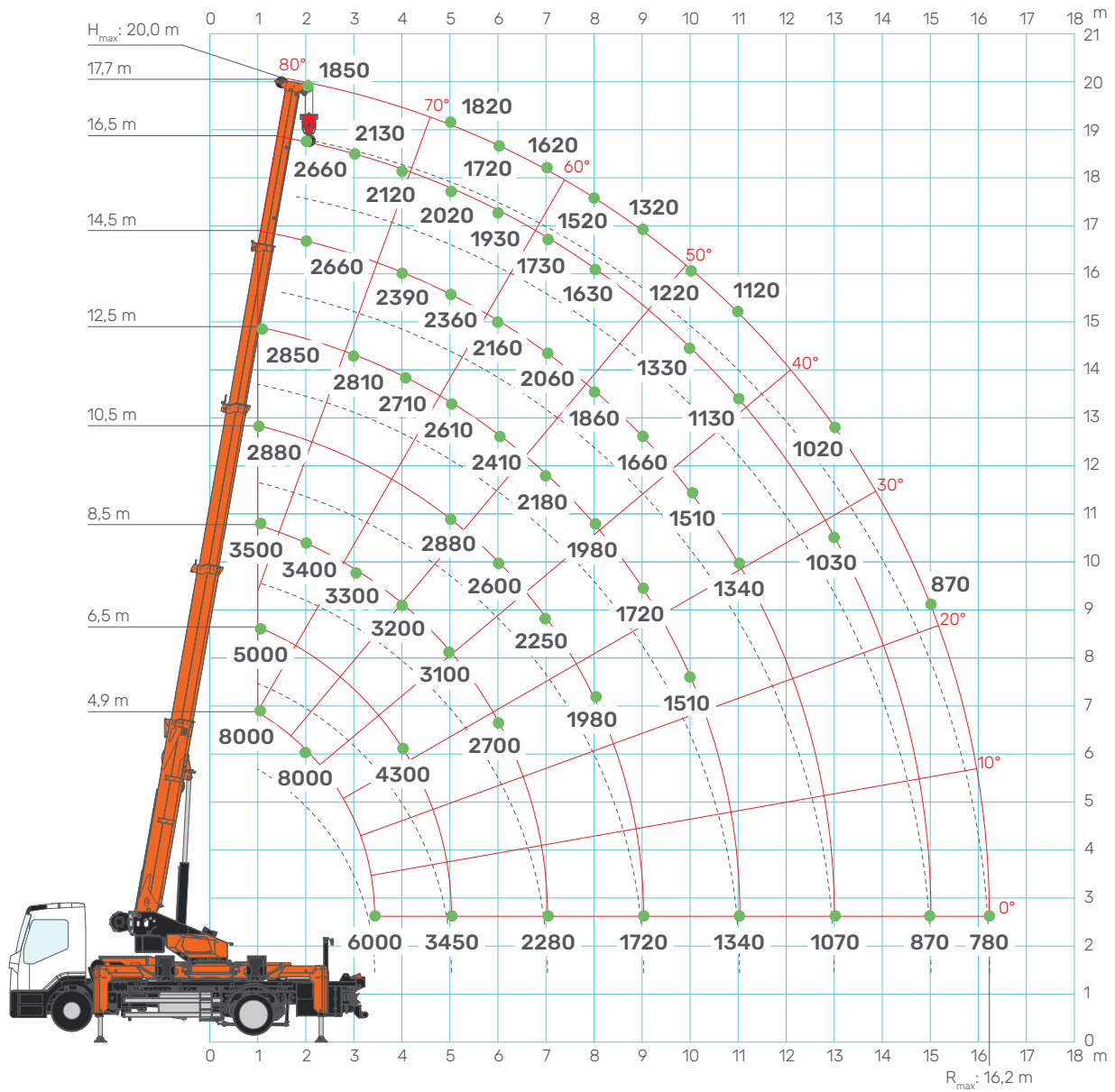

CRANE PERFORMANCE: J7

L [m]→	4,9	5,5	6,5	7,5	8,5	9,5	10,5	11,5	12,5	14,5	16,5	17,7
1	8000	6500	5000	4200	3500	3200	2880	2860	2850	2830	2820	1850
2	8000	6500	5000	4200	3400	3200	2880	2860	2850	2660	2660	1850
3	6000	5600	5000	4000	3300	3000	2880	2860	2810	2570	2130	1850
4		4580	4300	4000	3200	2900	2880	2860	2710	2390	2120	1850
5			3450	3300	3100	2900	2880	2760	2610	2360	2020	1820
6				2750	2700	2650	2600	2560	2410	2160	1930	1720
7					2280	2250	2250	2200	2180	2060	1730	1620
8						1980	1980	1980	1980	1860	1630	1520
9							1720	1720	1720	1660	1430	1320
10								1510	1510	1510	1330	1220
11									1340	1340	1130	1120
13										1070	1030	1020
15											870	870
16,2												780
↑R[m]	[kg]	T80__100EU_0426_C1J7										

CRANE PERFORMANCE: J6

L [m]→	4,9	5,5	6,5	7,5	8,5	9,5	10,5	11,5	12,5	14,5	16,5	17,7
1	8000	6500	5000	4200	3500	3200	2880	2860	2850	2830	2820	1850
2	8000	6500	5000	4200	3400	3200	2880	2860	2850	2660	2660	1850
3	5600	5500	5000	4000	3300	3000	2880	2860	2810	2570	2130	1850
4		4100	4050	4000	3200	2900	2880	2860	2710	2390	2120	1850
5			3180	3150	3100	2900	2880	2760	2610	2360	2020	1820
6				2500	2500	2500	2500	2500	2410	2160	1930	1720
7					2080	2080	2080	2080	2080	2060	1730	1620
8						1780	1780	1780	1780	1780	1630	1520
9							1550	1550	1550	1550	1430	1320
10								1350	1350	1350	1330	1220
11									1200	1200	1130	1120
13										950	950	950
15											750	750
16,2												640
↑R[m]	[kg]	T80__100EU_0426_C1J6										

CRANE PERFORMANCE: J5

L [m]→	4,9	5,5	6,5	7,5	8,5	9,5	10,5	11,5	12,5	14,5	16,5	17,7
1	8000	6500	5000	4200	3500	3200	2880	2860	2850	2830	2820	1850
2	8000	6500	5000	4200	3400	3200	2880	2860	2850	2660	2660	1850
3	5600	5500	5000	4000	3300	3000	2880	2860	2810	2570	2130	1850
4		4100	4050	4000	3200	2900	2880	2860	2710	2390	2120	1850
5			3130	3130	3100	2900	2880	2760	2610	2360	2020	1820
6				2250	2250	2250	2250	2250	2250	2160	1930	1720
7					1730	1730	1730	1730	1730	1730	1730	1620
8						1410	1410	1410	1410	1410	1410	1410
9							1180	1180	1180	1180	1180	1180
10								990	990	990	990	990
11									850	850	850	850
13										630	630	630
15											480	480
16,2												410
↑R[m]	[kg]	T80__100EU_0426_C1J5										

CRANE PERFORMANCE: J4

L [m]→	4,9	5,5	6,5	7,5	8,5	9,5	10,5	11,5	12,5	14,5	16,5	17,7
1	8000	6500	5000	4200	3500	3200	2880	2860	2850	2830	2820	1850
2	8000	6500	5000	4200	3400	3200	2880	2860	2850	2660	2660	1850
3	5450	4930	4680	4000	3300	3000	2880	2860	2810	2570	2130	1850
4		3080	3080	2990	2950	2900	2880	2860	2710	2390	2120	1850
5			2060	2060	2060	2060	2060	2060	2060	2060	2020	1820
6				1450	1450	1450	1450	1450	1450	1450	1450	1450
7					1090	1090	1090	1090	1090	1090	1090	1090
8						870	870	870	870	870	870	870
9							710	710	710	710	710	710
10								590	590	590	590	590
11									490	490	490	490
13										340	340	340
15											240	240
16,2												190
↑R[m]	[kg]	T80__100EU_0426_C1J4										

JIB3502GX

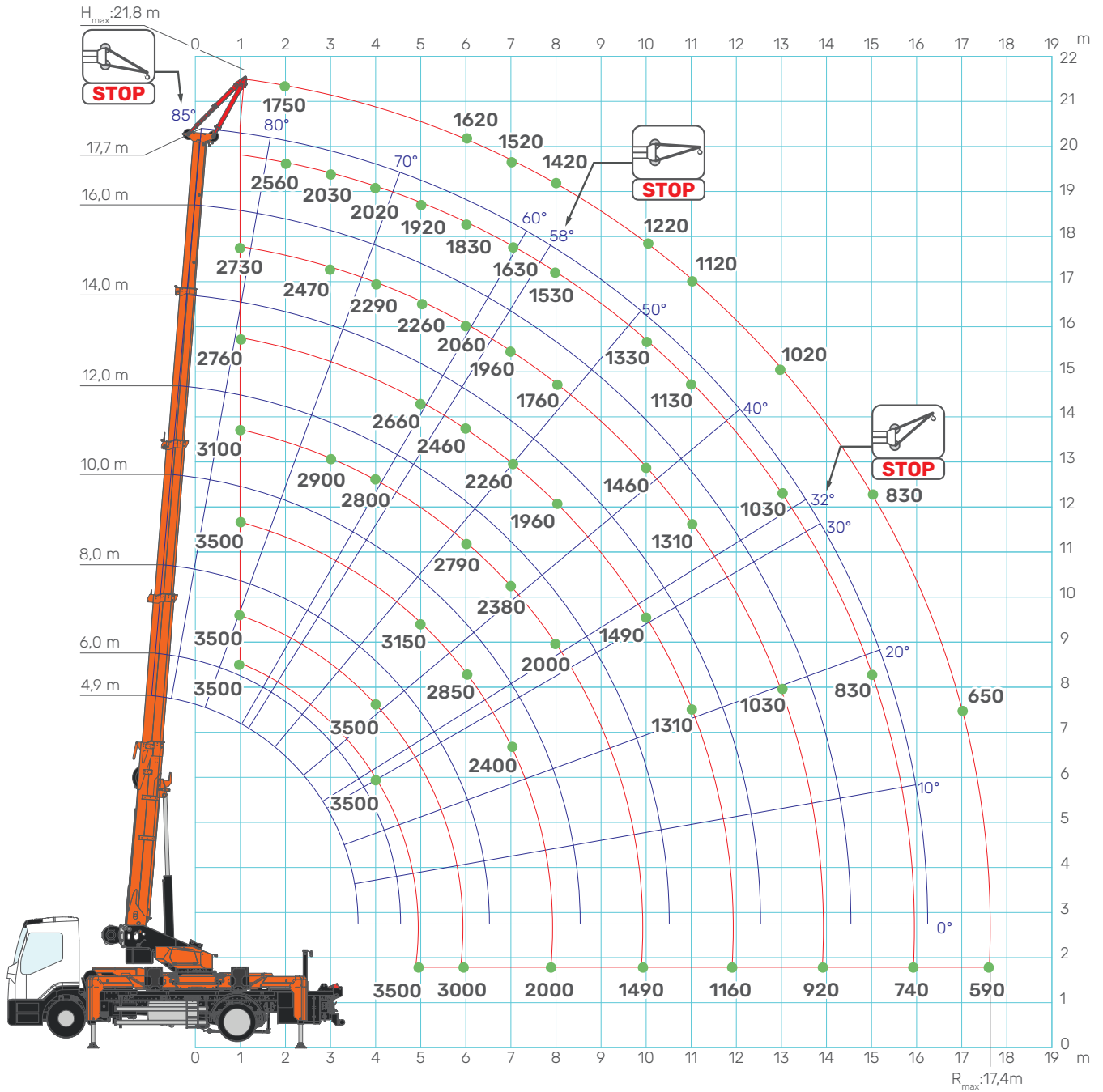

[kg] *The word "STOP" stands for the maximum working angle of the main boom for the displayed jib configuration.

CRANE PERFORMANCE: J7

L [m]→	4,9	6,0	7,0	8,0	9,0	10,0	11,0	12,0	14,0	16,0	17,7
1	3500	3500	3500	3500	3400	3100	2780	2760	2730	2720	1750
2	3500	3500	3500	3500	3300	3100	2780	2760	2560	2560	1750
3	3500	3500	3500	3500	3200	2900	2780	2760	2470	2030	1750
4	3500	3500	3500	3500	3100	2800	2780	2760	2290	2020	1750
5	3500	3500	3500	3150	3000	2800	2780	2660	2260	1920	1720
6		3000	2950	2850	2820	2790	2610	2460	2060	1830	1620
7			2420	2400	2380	2380	2300	2260	1960	1630	1520
8				2000	2000	2000	2000	1960	1760	1530	1420
10						1490	1490	1490	1460	1330	1220
11							1310	1310	1310	1130	1120
13									1030	1030	1020
15										830	830
17											650
17,4											590
↑R[m]	[kg]	T80__100EU_0426_C1J7									

CRANE PERFORMANCE: J6

L [m]→	4,9	6,0	7,0	8,0	9,0	10,0	11,0	12,0	14,0	16,0	17,7
1	3500	3500	3500	3500	3400	3100	2780	2760	2730	2720	1750
2	3500	3500	3500	3500	3300	3100	2780	2760	2560	2560	1750
3	3500	3500	3500	3500	3200	2900	2780	2760	2470	2030	1750
4	3500	3500	3500	3500	3100	2800	2780	2760	2290	2020	1750
5	3500	3500	3500	3150	3000	2800	2780	2660	2260	1920	1720
6		3000	2950	2850	2820	2790	2610	2460	2060	1830	1620
7			2420	2400	2380	2380	2300	2260	1960	1630	1520
8				2000	2000	2000	2000	1960	1760	1530	1420
10						1450	1450	1450	1450	1330	1220
11							1240	1240	1240	1130	1120
13									940	940	940
15										730	730
17											570
17,4											520
↑R[m]	[kg]	T80__100EU_0426_C1J6									

CRANE PERFORMANCE: J5

L [m]→	4,9	6,0	7,0	8,0	9,0	10,0	11,0	12,0	14,0	16,0	17,7
1	3500	3500	3500	3500	3400	3100	2780	2760	2730	2720	1750
2	3500	3500	3500	3500	3300	3100	2780	2760	2560	2560	1750
3	3500	3500	3500	3500	3200	2900	2780	2760	2470	2030	1750
4	3500	3500	3500	3500	3100	2800	2780	2760	2290	2020	1750
5	3430	3400	3320	3150	3000	2800	2780	2660	2260	1920	1720
6		2470	2440	2420	2420	2420	2420	2410	2060	1830	1620
7			1840	1830	1830	1830	1830	1830	1830	1630	1520
8				1410	1410	1410	1410	1410	1410	1410	1410
10						980	980	980	980	980	980
11							830	830	830	830	830
13									600	600	600
15										450	450
17											330
17,4											290
↑R[m]	[kg]	T80__100EU_0426_C1J5									

CRANE PERFORMANCE: J4

L [m]→	4,9	6,0	7,0	8,0	9,0	10,0	11,0	12,0	14,0	16,0	17,7
1	3500	3500	3500	3500	3400	3100	2780	2760	2730	2720	1750
2	3500	3500	3500	3500	3300	3100	2780	2760	2560	2560	1750
3	3500	3500	3500	3500	3200	2900	2780	2760	2470	2030	1750
4	3420	3190	3020	2870	2850	2800	2780	2760	2290	2020	1750
5	2330	2300	2210	2100	2090	2090	2090	2080	2050	1920	1720
6		1650	1620	1590	1590	1590	1590	1590	1590	1590	1570
7			1190	1180	1180	1180	1180	1180	1180	1180	1180
8				870	870	870	870	870	870	870	870
10						570	570	570	570	570	570
11							470	470	470	470	470
13									310	310	310
15										200	200
16										150	150
16,8											110
↑R[m]	[kg]	T80__100EU_0426_C1J4									

JIB1502.3HX

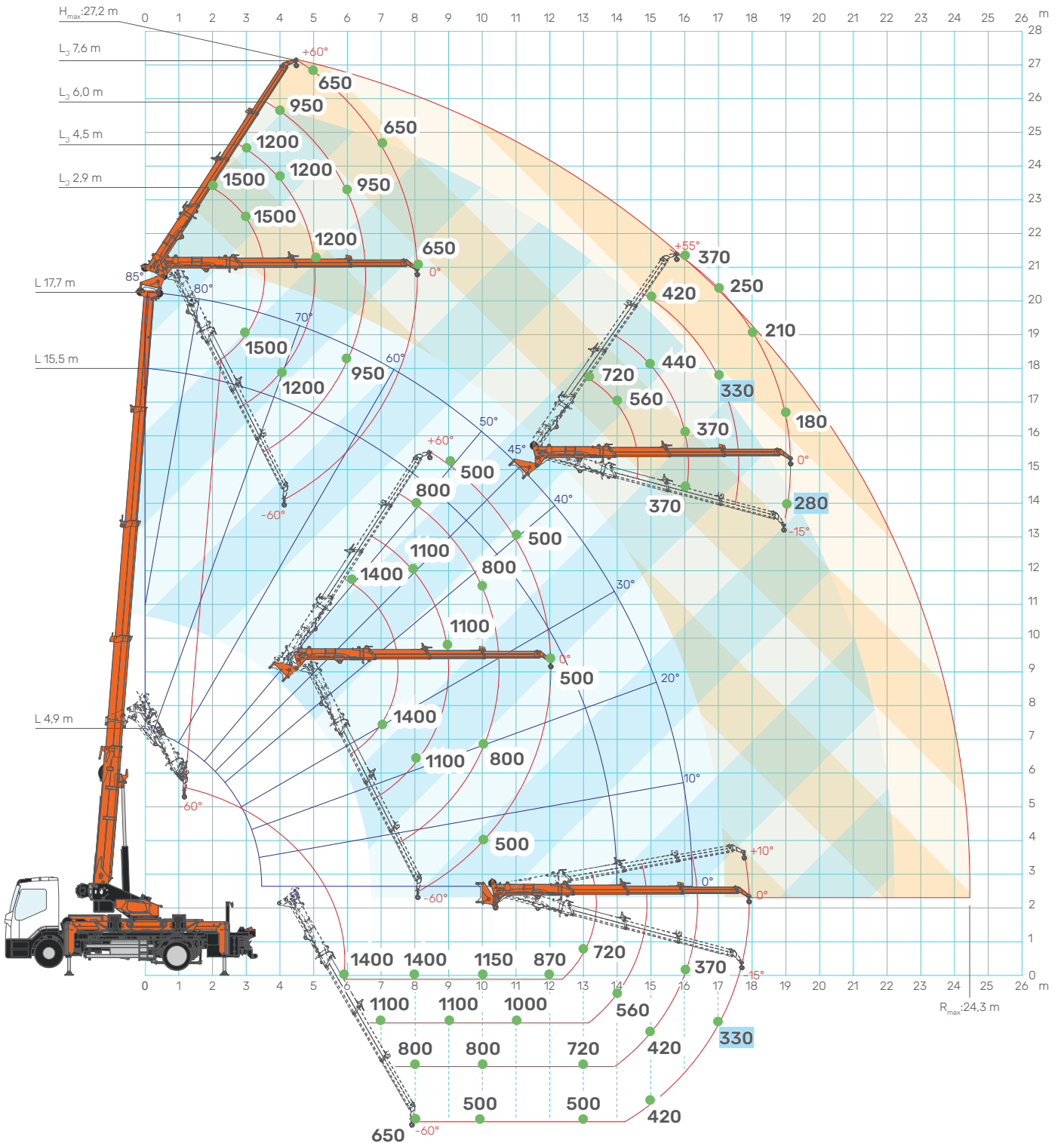

*Over 10 m main boom radius, the minimum jib angle is limited at -15°

[kg]

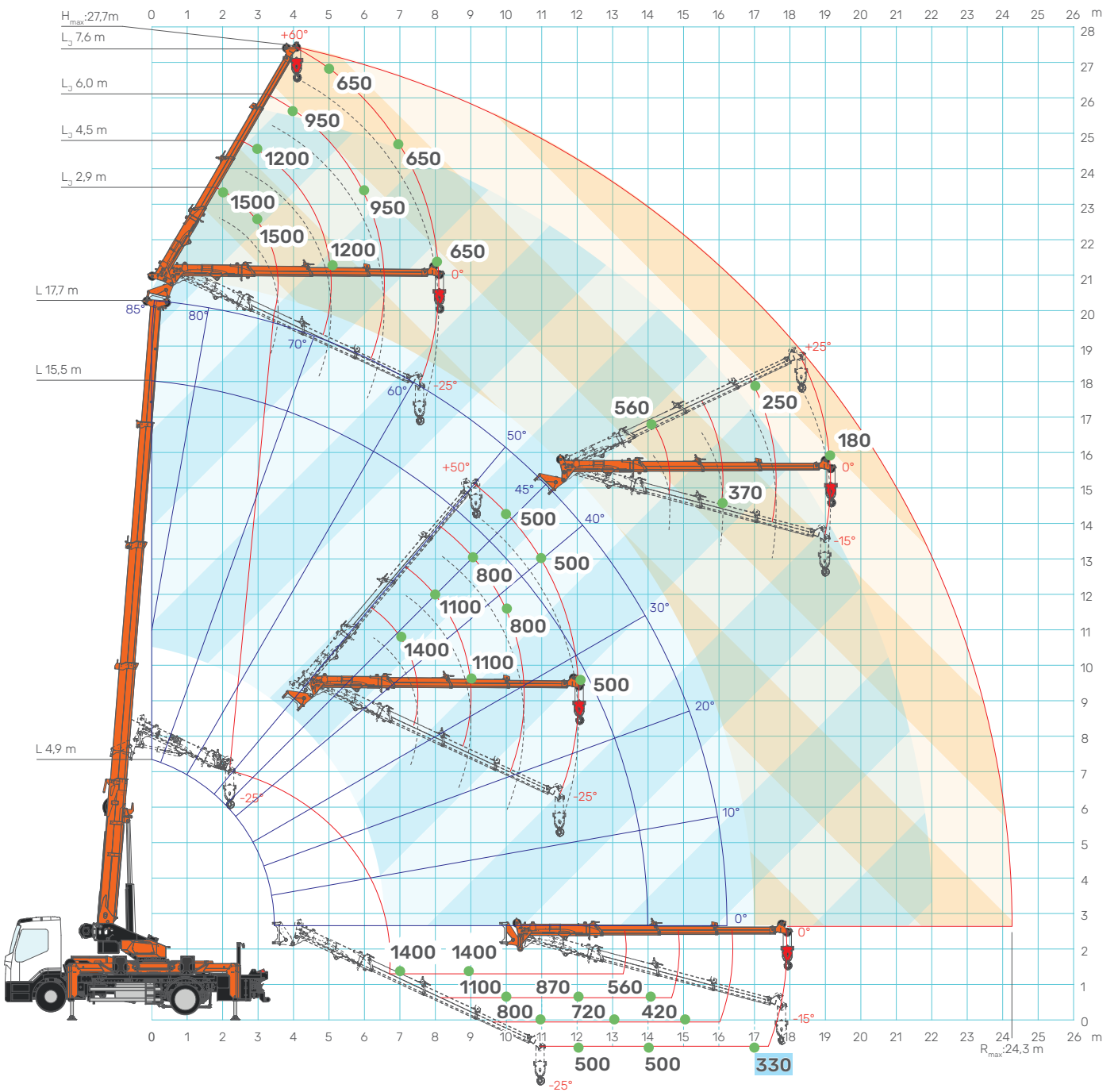

[kg] *Over 10 m main boom radius, the minimum jib angle is limited at -15°

CRANE PERFORMANCE: J7 (4,9 m < L < 15,5 m)

L [m]→	2,9	4,5	6,0	7,6
1	1500	1200	950	650
4	1500	1200	950	650
5	1400	1200	950	650
6	1400	1100	950	650
7	1400	1100	950	650
8	1400	1100	800	650
9	1400	1100	800	500
10	1150	1100	800	500
11	1050	1000	800	500
12	870	870	800	500
13	720	720	720	500
14	560	560	560	500
15	440	440	420	420
16	370	370	370	370
17	340	330	330	330
18		330	330	330
19		280	280	280
20			260	260
21				260
22				220
22,1				220
↑R[m]	[kg]	T80__100EU_0426_C1J1		

CRANE PERFORMANCE: J7 (L > 15,5 m)

L [m]→	2,9	4,5	6,0	7,6
1	1500	1200	950	650
4	1500	1200	950	650
5	1400	1200	950	650
6	1400	1100	950	650
7	1400	1100	950	650
8	1400	1100	800	650
9	1400	1100	800	500
10	1150	1100	800	500
11	1050	1000	800	500
12	870	870	800	500
13	720	720	720	500
14	560	560	560	500
15	440	440	420	420
16	370	370	370	370
17	250	250	250	250
18	210	210	210	210
19	180	180	180	180
20		150	150	150
21		130	130	130
22			120	120
23				110
24,3				100
↑R[m]	[kg]	T80__100EU_0426_C1J7		

CRANE PERFORMANCE: J6

L [m]→	2,9	4,5	6,0	7,6
1	1500	1000	800	500
2	1500	1000	800	500
3	1500	1000	800	500
4	1500	1000	800	500
5	1400	1000	800	500
6	1400	1000	800	500
7	1400	1000	800	500
8	1400	1000	800	500
9	1330	1000	800	500
10	1050	1000	800	500
11	840	840	800	500
12	660	660	660	500
13	510	510	510	500
14	390	390	390	390
15	290	290	290	290
16	200	200	200	200
16,8	120	120	120	120
↑R[m]	[kg]	T80_100EU_0426_C1J6		

CRANE PERFORMANCE: J5

L [m]→	2,9	4,5	6,0	7,6
1	1500	1000	800	500
2	1500	1000	800	500
3	1500	1000	800	500
4	1500	1000	800	500
5	1400	1000	800	500
6	1400	1000	800	500
7	1350	1000	800	500
8	1060	1000	800	500
9	780	780	780	500
10	580	580	580	500
11	420	420	420	420
12	280	280	280	280
12,8	180	180	180	180
↑R[m]	[kg]	T80__100EU_0426_C1J5		

CRANE PERFORMANCE: J4

L [m]→	2,9	4,5	6,0	7,6
1	1500	1000	800	500
2	1500	1000	800	500
3	1500	1000	800	500
4	1500	1000	800	500
5	1400	1000	800	500
6	1030	1000	800	500
7	750	750	750	500
8	530	530	530	500
9	310	310	310	310
9,8	170	170	170	170
↑R[m]	[kg]	T80__100EU_0426_C1J4		

ACCESSORIES

JIB1502.3HX

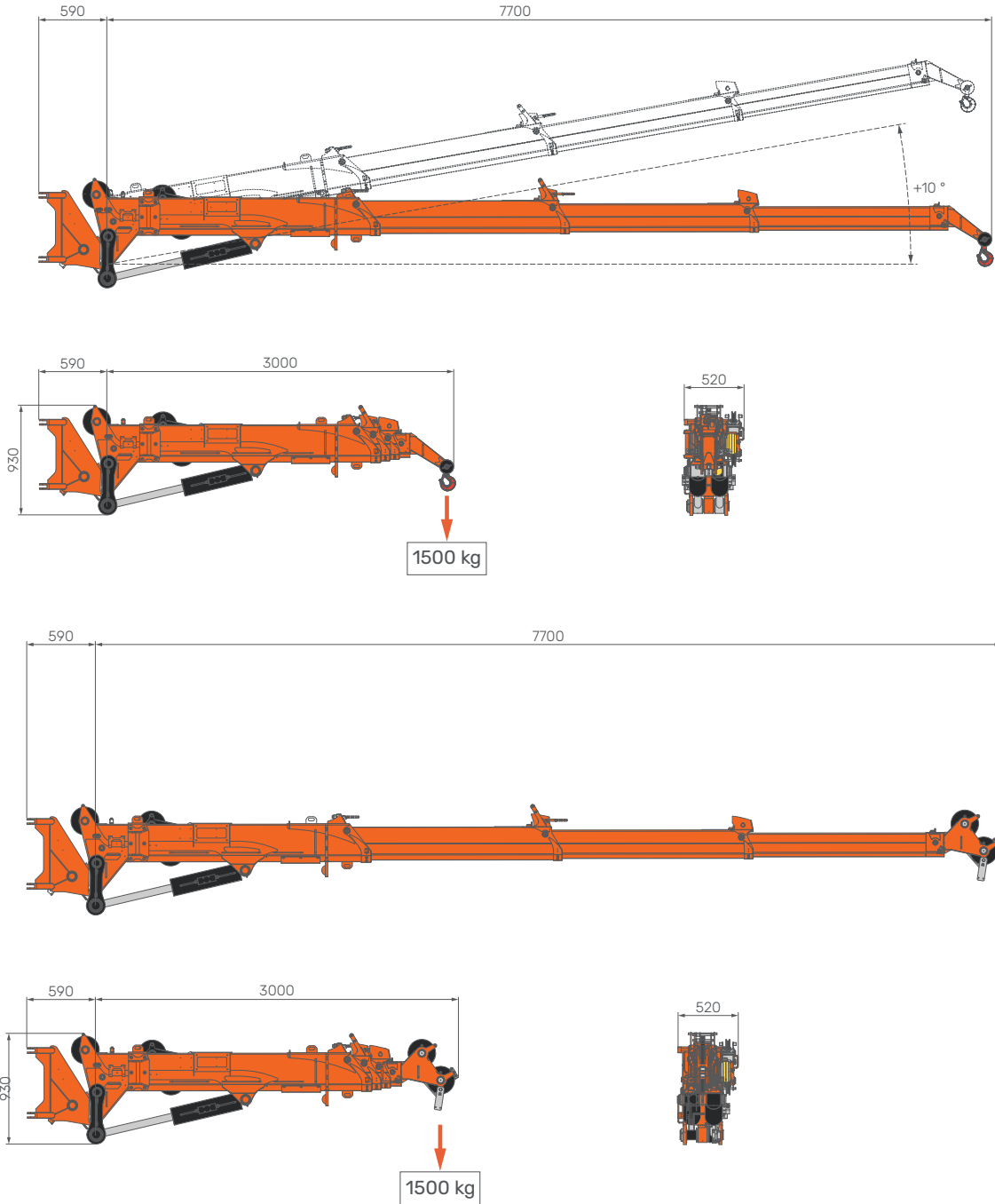

WEIGHT



JIB	JIB1502.3HX	kg	675
-----	-------------	----	-----

[mm]

JIB3502GX

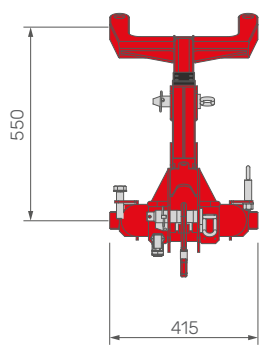
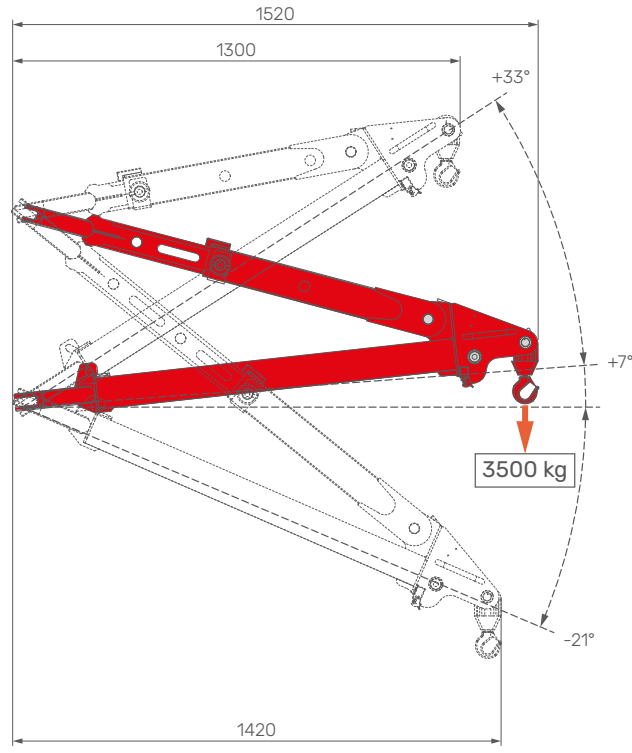

WEIGHT



JIB	JIB3502GX	kg	70
-----	-----------	----	----

SYMBOLS

	Weight		Outriggers Mats		Main Boom Lifting		Hydraulic System
	Crane		Powerpack		Boom Length		Electric Motorization
	Maximum Axle Load		Hookblock		Jib		Working Temperature
	Electric Motorization		Maximum Capacity		Turret Slewing		Hydraulic Activation
	Maximum Wind Load		Maximum Outriggers Load		Winch		Hook
	Electric System						

LOAD CHARTS REMARKS

- Load tables have been calculated following the EN 13000:2014 standard.
- Load tables have been calculated considering a wind load of 13,8 m/s, a sail area of 1m²/t and a drag coefficient of 1,2.
- Load capacities are given in kg.
- Hookblocks and hooks weight is part of the load, hence it shall be deducted from the capacity values.
- The working radius is measured form the turret slewing center.
- The supplied Technical Data is part of the Use & Maintenance Manual.
- Features and specifications may change without prior advice.
- All indicated data are for informational purposes only and are not binding as the crane performs differently depending on its use.



Jekko s.r.l.

Via Galileo Galilei, 6/8 – 31010 Godega di Sant’Urbano (TV) – Italy
info@jekko.it – www.jekko-cranes.com

SERIAL NUMBER:



08.06.2026 | REV0.1