

JFS45 VMAX



MAIN BOOM

6 telescopic sections, 360-degrees continuous rotation, max lifting capacity of 15.5 t

3 ton HYDRAULIC JIB

6 telescopic sections, maximum working height 30 m, maximum outreach of 28 m, 20° negative angle



ADDITIONAL ELECTRIC ENGINE

Possibility of working without any kind of emission



DEDICATED HYDRAULIC EXTRA FUNCTION

On main boom and jib, with additional oil cooler, allowing the use of a wider range of tools whose operation require elevated quantity and pressure of oil.



GREAT ACCESSIBILITY

Even in the most confined places, thank to the compact dimensions



X-PATTERN OUTRIGGERS

With hydraulic rotation between 0° and 45° and endless operational configurations

ONE TOOL, MANY OPERATIONS

Possibility of cutting, resting on the ground and sorting the branches or trunks using grapple saw

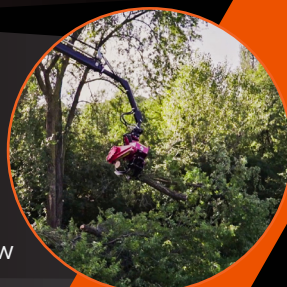

MORE PRECISE WORK

By bringing the machine near the working area



SAFER JOB FOR THE OPERATOR

Thanks to the possibility of managing all crane and tool movements with radio remote control from safety distance



JFS45 VMAX

Grapple Saw Application



Jekko srl
Via Campardone, 1 - 31014 Colle Umberto (TV) Italy
info@jekko.it - www.jekko-cranes.com

Product Catalog

Technical Information

Dimensions	L x W x H	5,45 x 1,89 x 2,93 m
Footprint	Min	4,25 x 4,25 m
	Max	6,7 x 6,7 m

Crane & Options Weights		Kg
JF545		13700
Counterweight		3500
Pulley Block		60
Winch		200
Power Pack		80
JIB3000.6HA		1200
Basket		200
White Pads		300

Winch	2000 kg single line 60 m - Ø 12 mm
-------	---------------------------------------

JFS45	Diesel Engine	KUBOTA V3307-CR-TE4B	55,4 kW 74 Hp
	Electric Power Pack	400V-3F	13 kW 17,4 Hp

Speed	2.5 km/h
-------	----------

Gradeability	20°
--------------	-----

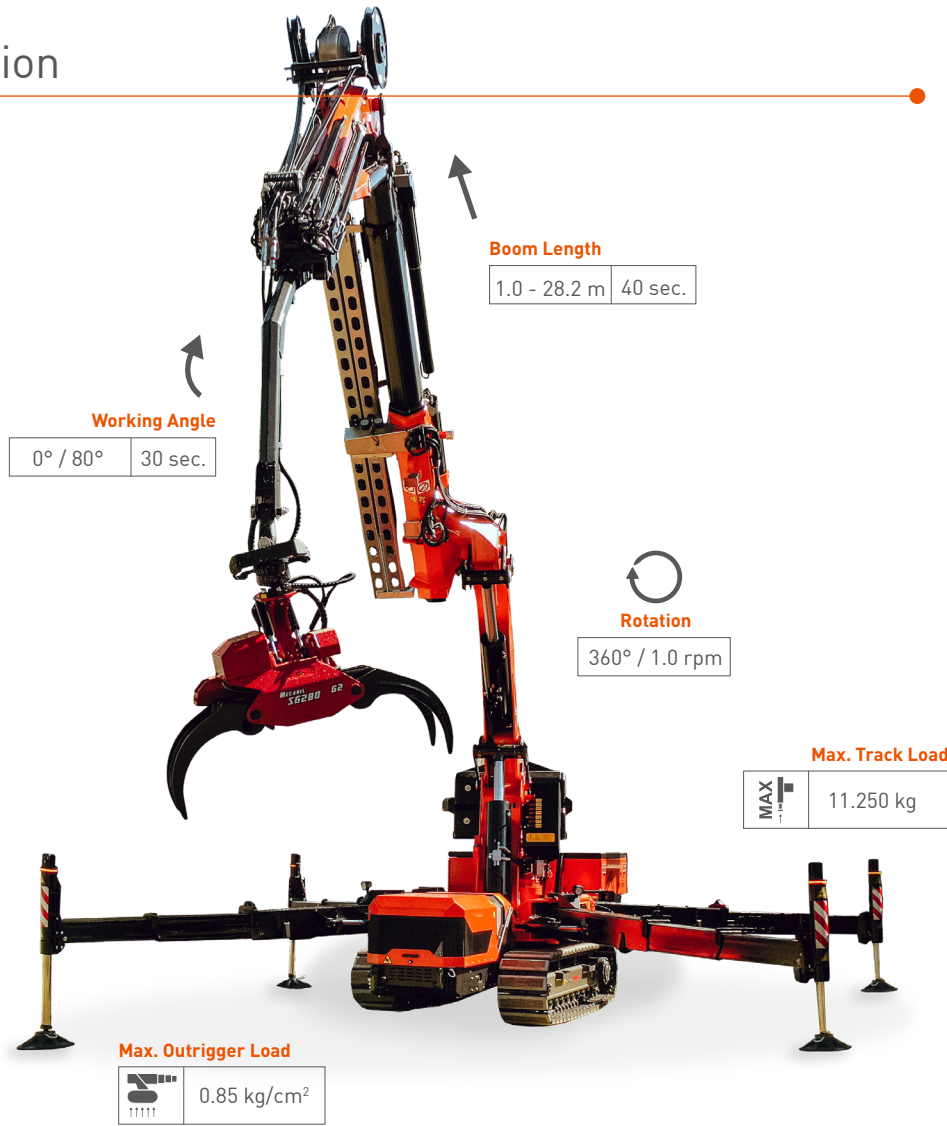

Grapple Saw

SG160RC-T-G2 (GRAPPLE-SAW-160 KIT)	
Cutting diameter	Saw 16" » 350 mm
Opening of grapple	925 mm - 36.5"
Rec. work. pressure	180-230 bar
Rec. oil flow rate	40-80 l/min 10-25 GPM
Grapple size	0,16 m²
Weight	220 kg

SG280RC-T-G2 (GRAPPLE-SAW-280 KIT)	
Cutting diameter	Saw 22" » 550 mm Saw 25" » 630 mm
Opening of grapple	1490 mm - 59"
Rec. work. pressure	180-230 bar
Rec. oil flow rate	60-100 l/min 15-30 GPM
Grapple size	0,30 m²
Weight	390 kg

Load Chart

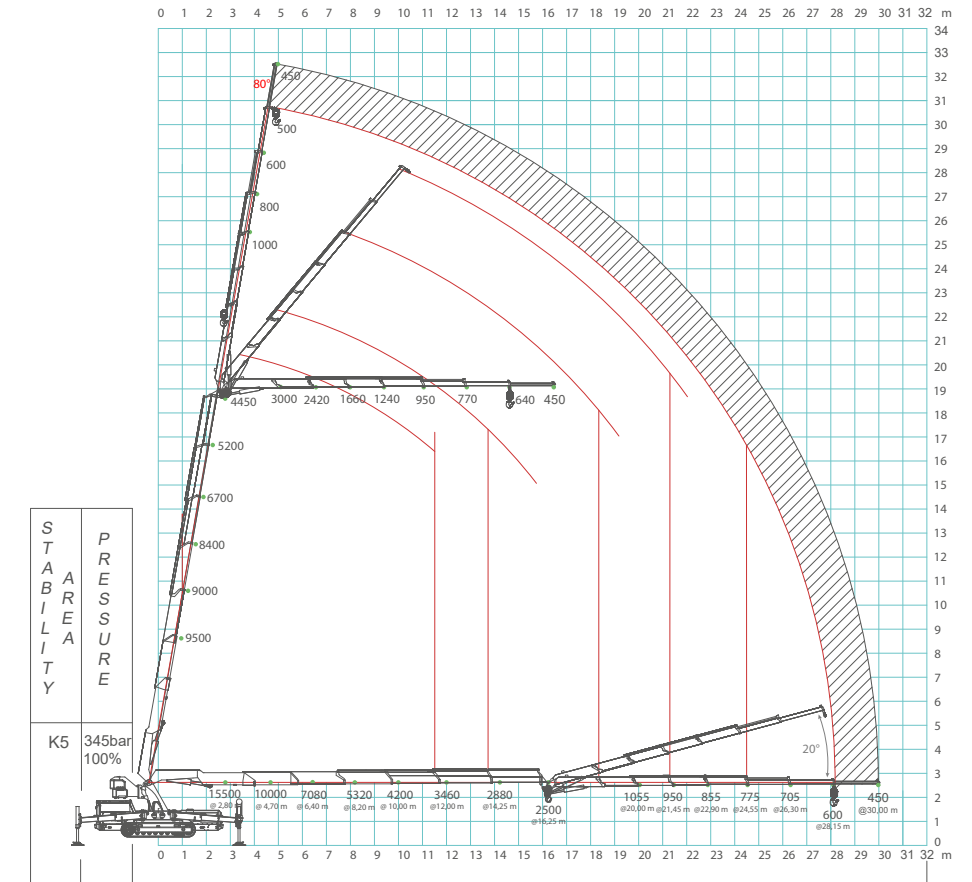

Crane Options

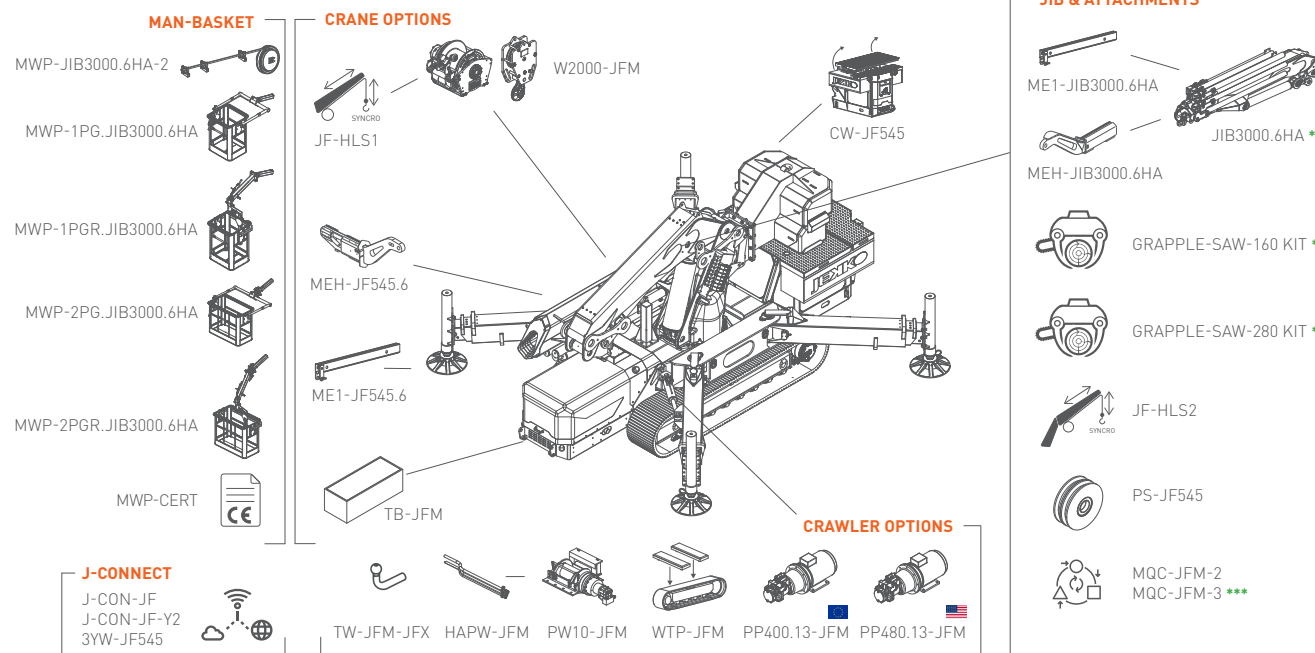

Dimensions & Footprint

