



Technical Data

Specification & Capacities

JF545



EN 12999:2020

29.08.2024 | Rev3.0

[m] [kg]

OVERALL DIMENSIONS

(with jib and low marking pads)

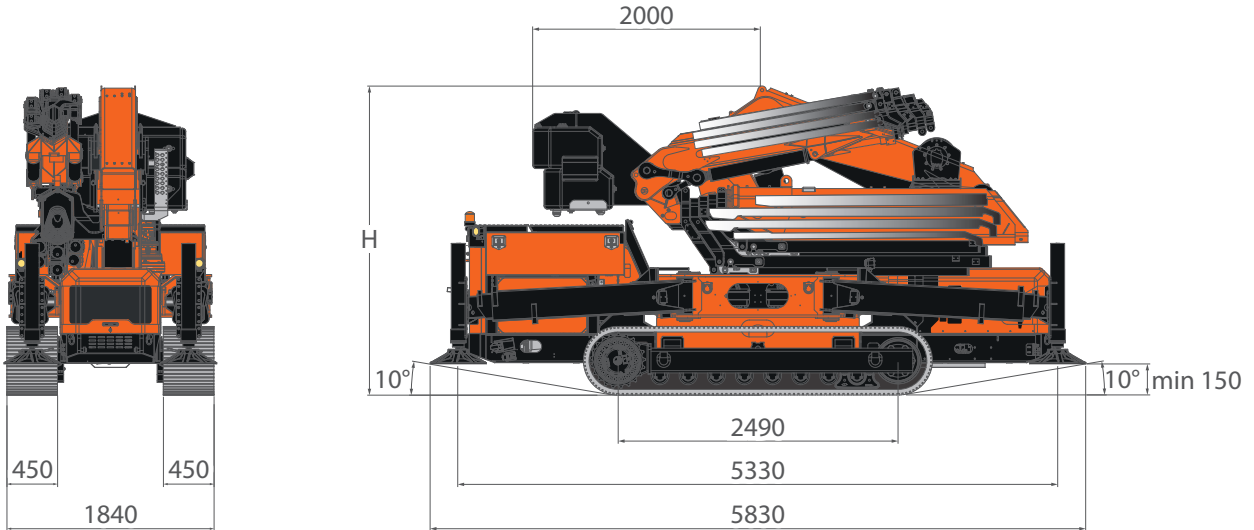

H	WITH V20 winch	2830
	WITH V30 winch	2900

STABILITY AREAS

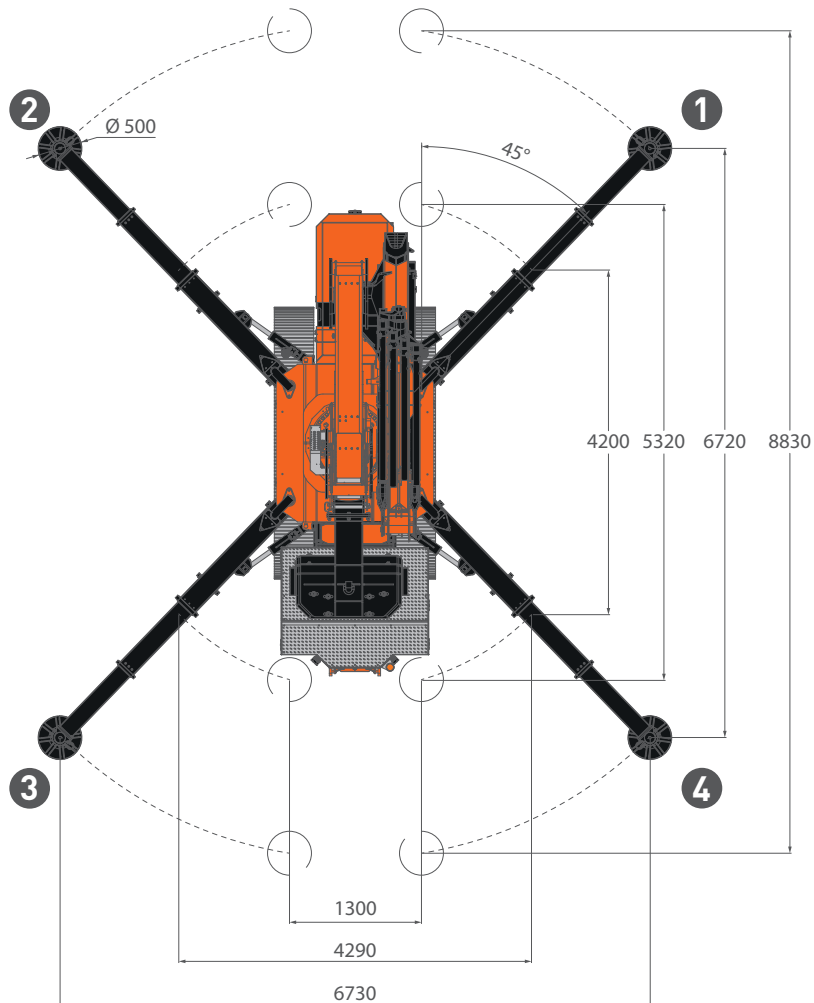

Min stability angle: 0°
Max stability angle: 45°

[mm]

STABILIZATION ADJUSTMENT

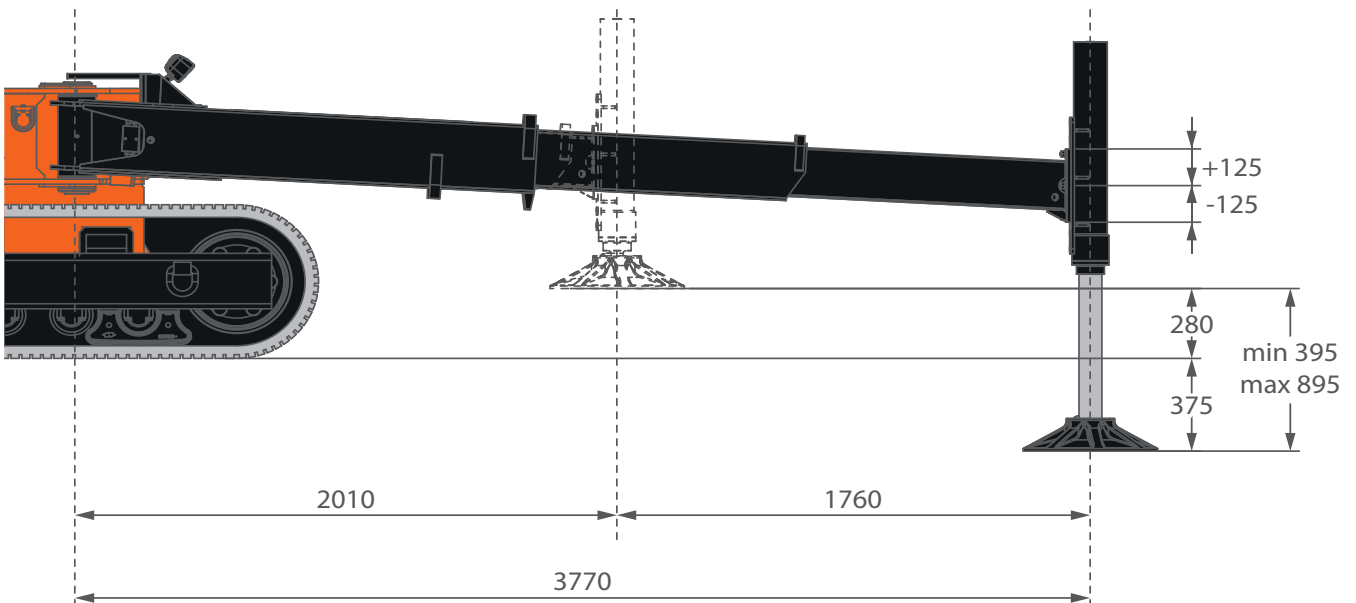
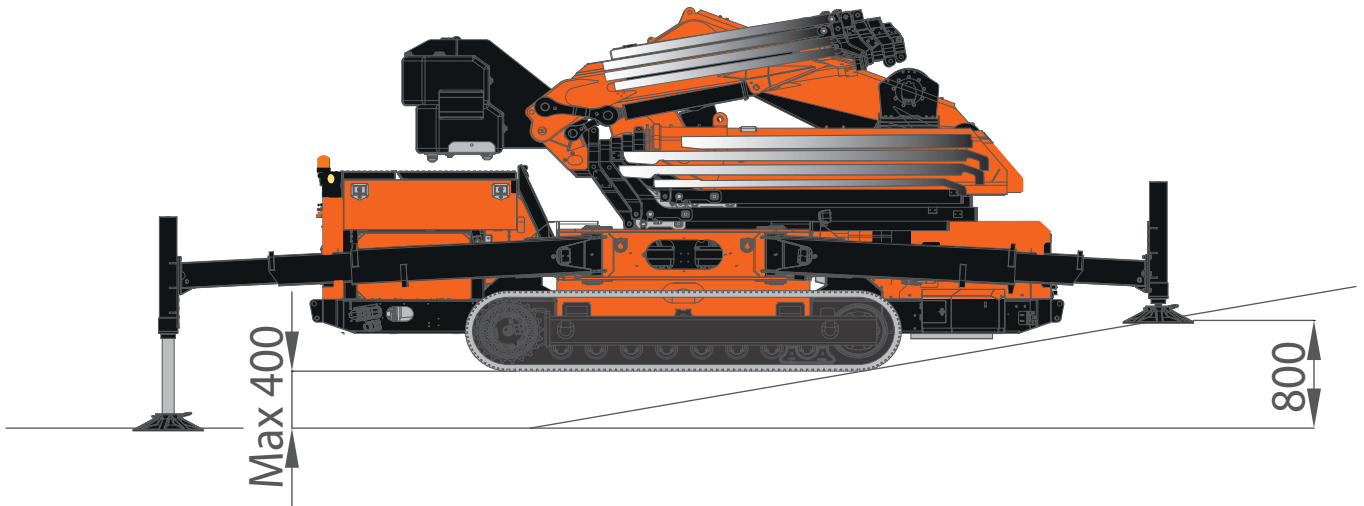

[mm]

OVERALL INFORMATIONS

		DESCRIPTION	U.M	VALUE	
CRANE INFO	 OVERALL DIMENSIONS	Height	mm	2.830	
		Length		5.830	
		Width		1.840	
	 BOOM	Length	m	16,3	
		Speed	s	42*	
	 SLEWING	Angle	°	360°	
		Speed	rpm	0,67	
	 LIFTING	Working Angle	°	0°/80°	
		Speed	s	Primary: 37 Secondary: 47	
		Max Capacity	kg	15.500	
		Max Outrigger Bearing Load	kg	11.250 [†]	
		Track load	kg/cm ²	0,85	
		Travel Speed	Slow	km/h	1
			Fast		2
	Gradeability	°	20° (36%) [‡]		
	Working Temperature	°C	-10°/+40°		

*: Timing without load, fully stabilized and without XP







[†]: Static lifting

[‡]: Engine work limit

OVERALL INFORMATIONS

WEIGHT		CRANE	JF545 (with activation)	kg	13.700* †
			Counterweight		3.500



HOOKBLOCKS		HOOK BLOCK	Single Fall	kg	47
			Double Fall		58
			Single Fall Jib		74

ACCESSORIES		JIB	JIBL426	With activation	kg	1.260
				Without activation		1.140
		MANUAL EXTENSIONS	ME1-545.6	kg	95	
			ME2-545.6		70	
			ME3-545.6		45	
			MEH-545.6		90	
			MEH-JIB3000.6HA		23	
			ME1-JIB3000.6HA		36	
		LOW MARKING PADS	WTP-JFM (x92)	kg	300	
		OUTRIGGERS MATS	OM500 (x4)	kg	92	
		POWERPACK	3-Phase Power pack	kg	80	
		PLE	MWP-2PG.JIB3000.6HA	kg	150	
			MWP-2PGR.JIB3000.6HA		207	

*: Dry weight

†: Estimated fluids weight = 150 kg

OVERALL INFORMATIONS

ENGINE		DIESEL ENGINE	Power		
			kW	55,4	
			HP	74	
	Tank capacity		L	75	
		ELECTRIC	Voltage		
			V	400	
		Power		kW	13

HYDRAULIC SYSTEM		Maximum Working Pressure		bar	345	
		Tank Capacity		L	200	
		OIL	Type		Mineral	ISO 6743-4:HV
			Viscosity Grade		VG	46
		DIESEL MAIN PUMP	Type		Variable Flow Pump LS	
			Displacement		cm ³ /rev	80
			Max Oil Flow		L/min	160
		ELECTRIC MAIN PUMP	Type		Variable Flow Pump LS	
			Displacement		cm ³ /rev	45
			Max Oil Flow		L/min	60

WINCH PERFORMANCE

W2000-JFM

WINCH	Layer		Max pull line	Standard rope speed
			daN	m/min
	1		2.000*	45
4		-*	57,5	
ROPE	Wire rope	Max load	Ø	Total length
		daN	mm	m
	19x7 avvolgimento destro. Anti-Rotazione	12.750	12	60

HOOK BLOCK	Block type	Load	N° of	
		kg	Sheaves	Lines
	Single fall block	2.000	-	1
Double fall block	3.500	1	2	
Triple fall block	6.000	1	3	

W3000-JFM

WINCH	Layer		Max pull line	Standard rope speed
			daN	m/min
	1		3.000†	28
3		-†	36	
ROPE	Wire rope	Max load	Ø	Total length
		daN	mm	m
	19x7 avvolgimento destro. Anti-Rotazione	18.600	14	60

HOOK BLOCK	Block type	Load	N° of	
		kg	Sheaves	Lines
	Single fall block	3.000	-	1
Double fall block	6.000	1	2	

*: LMI limited at 2.000 kg

†: LMI limited at 3.000 kg

CRANE PERFORMANCE

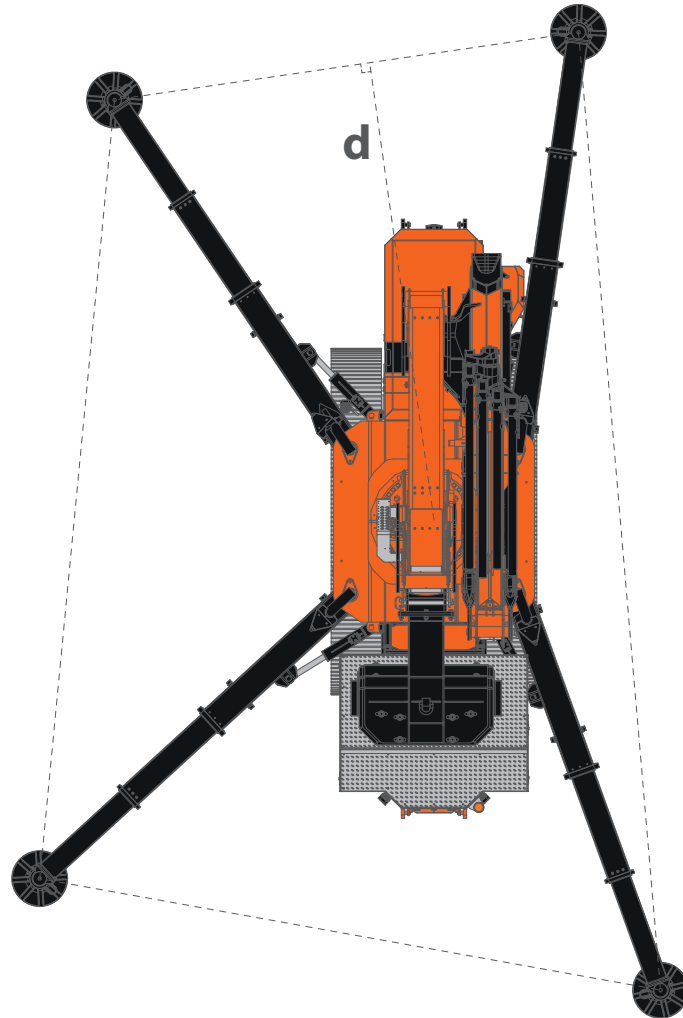

K	d min	d max
K1	1,6 m	2,0 m
K2	2,0 m	2,6 m
K3	2,6 m	3,1 m
K4	3,1 m	3,2 m
K5	3,2 m	-

JF545 - MAIN BOOM

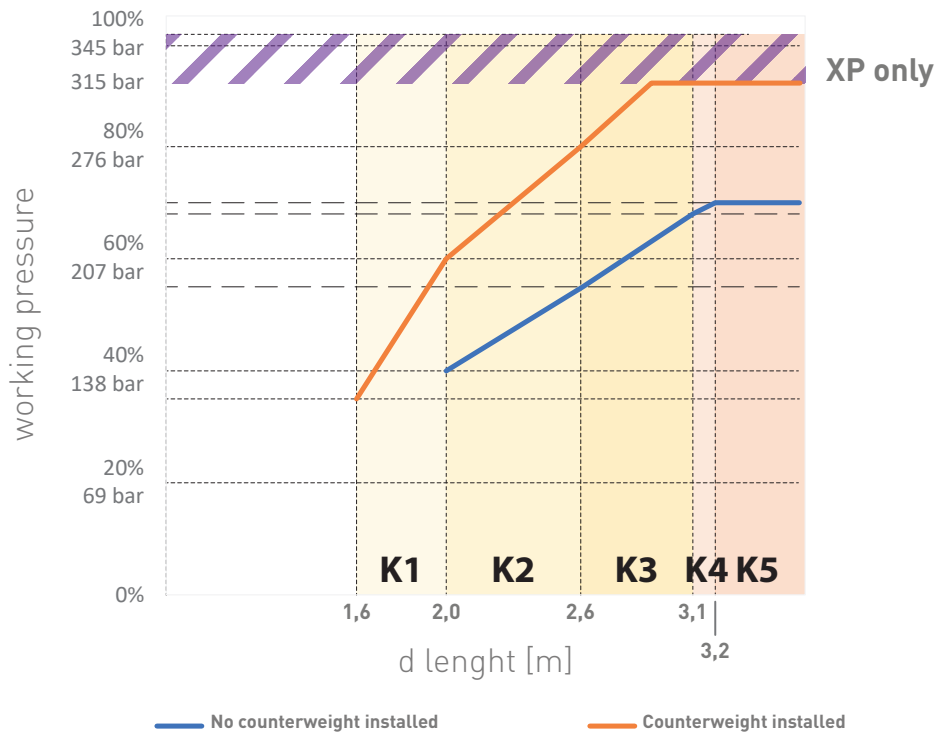
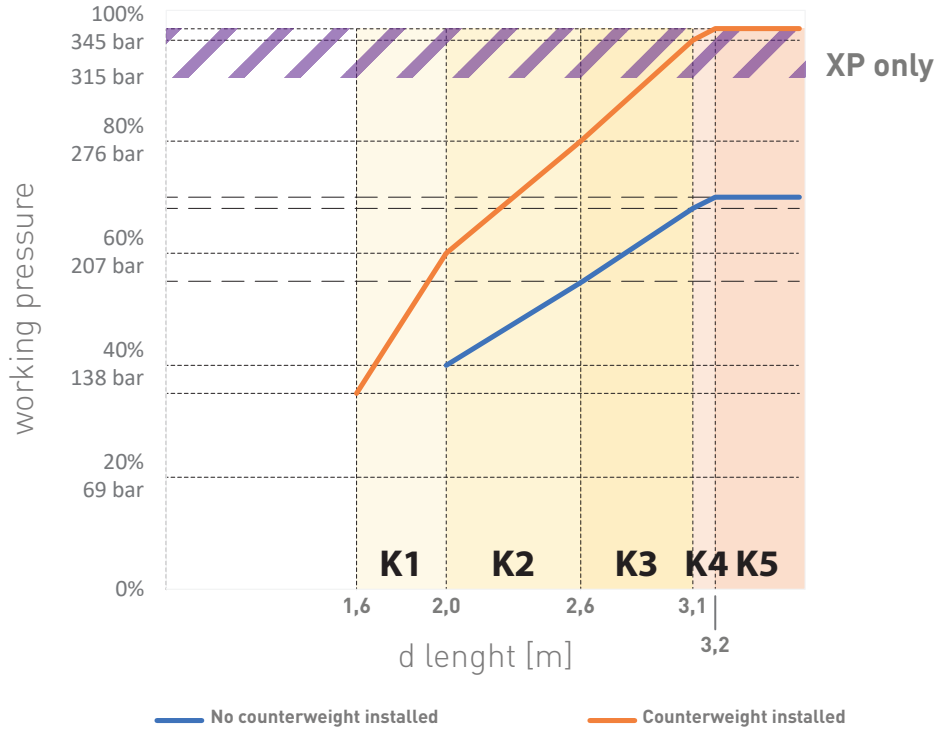

JF545 - JIB3000.6HA

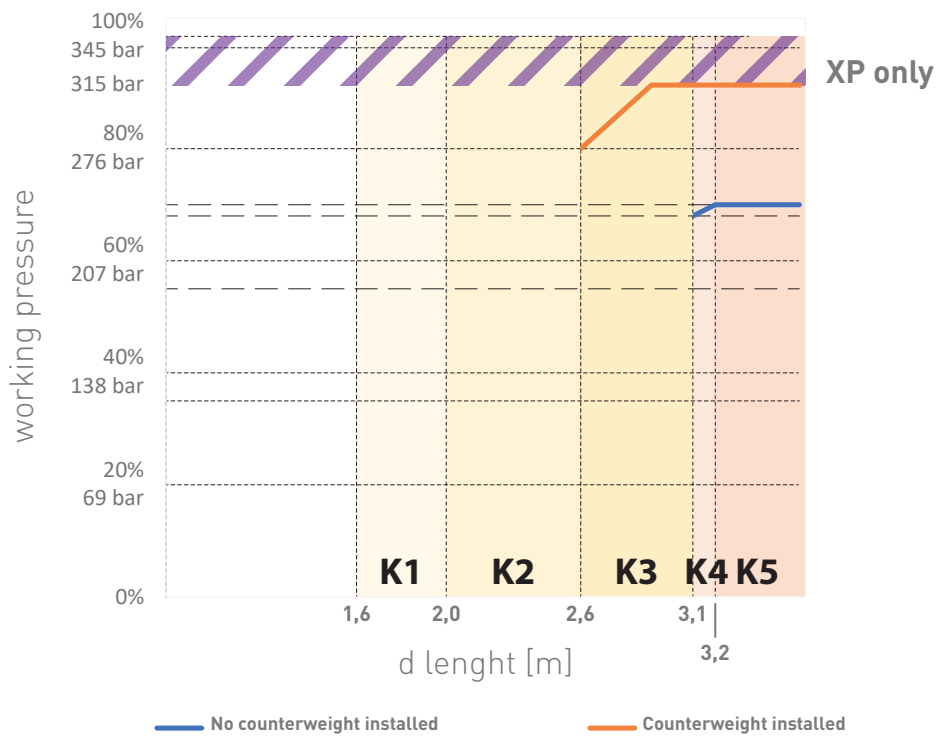
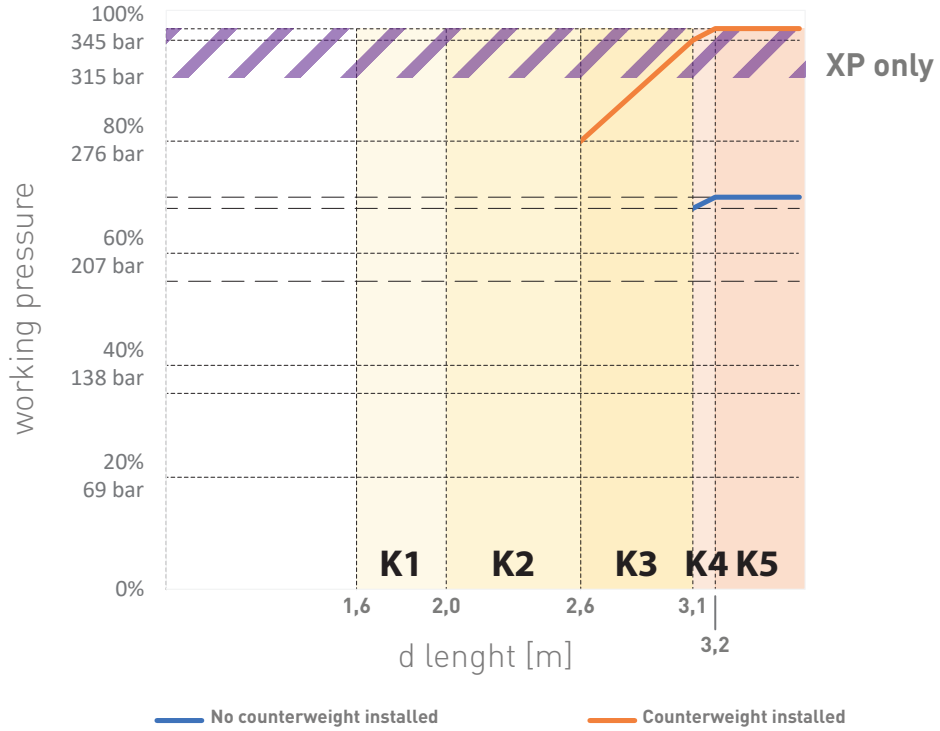

JF545 - MAIN BOOM

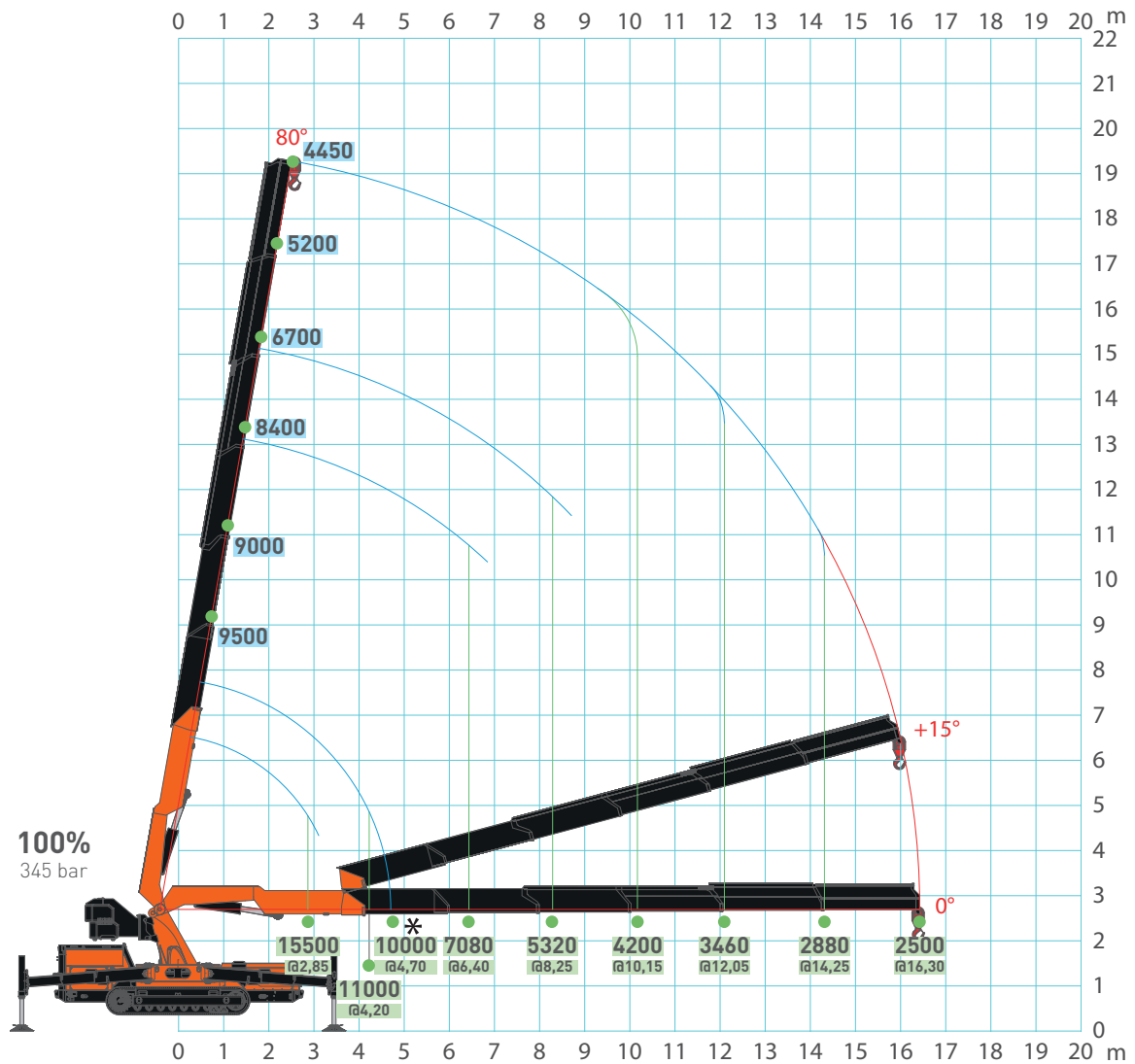

80%
276 bar

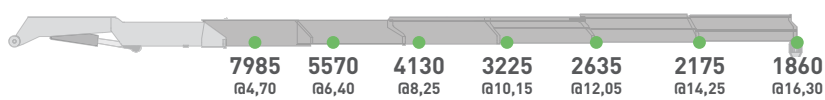

60%
207 bar

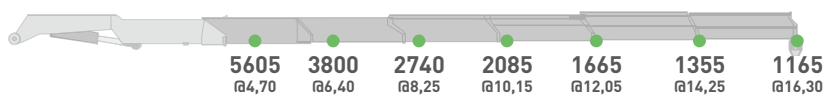

40%
138 bar



20%
69 bar

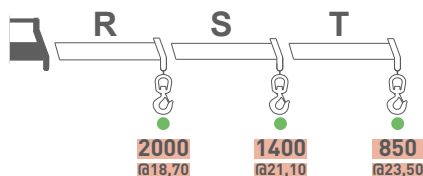

[m] [kg]

JF545 - MAIN BOOM

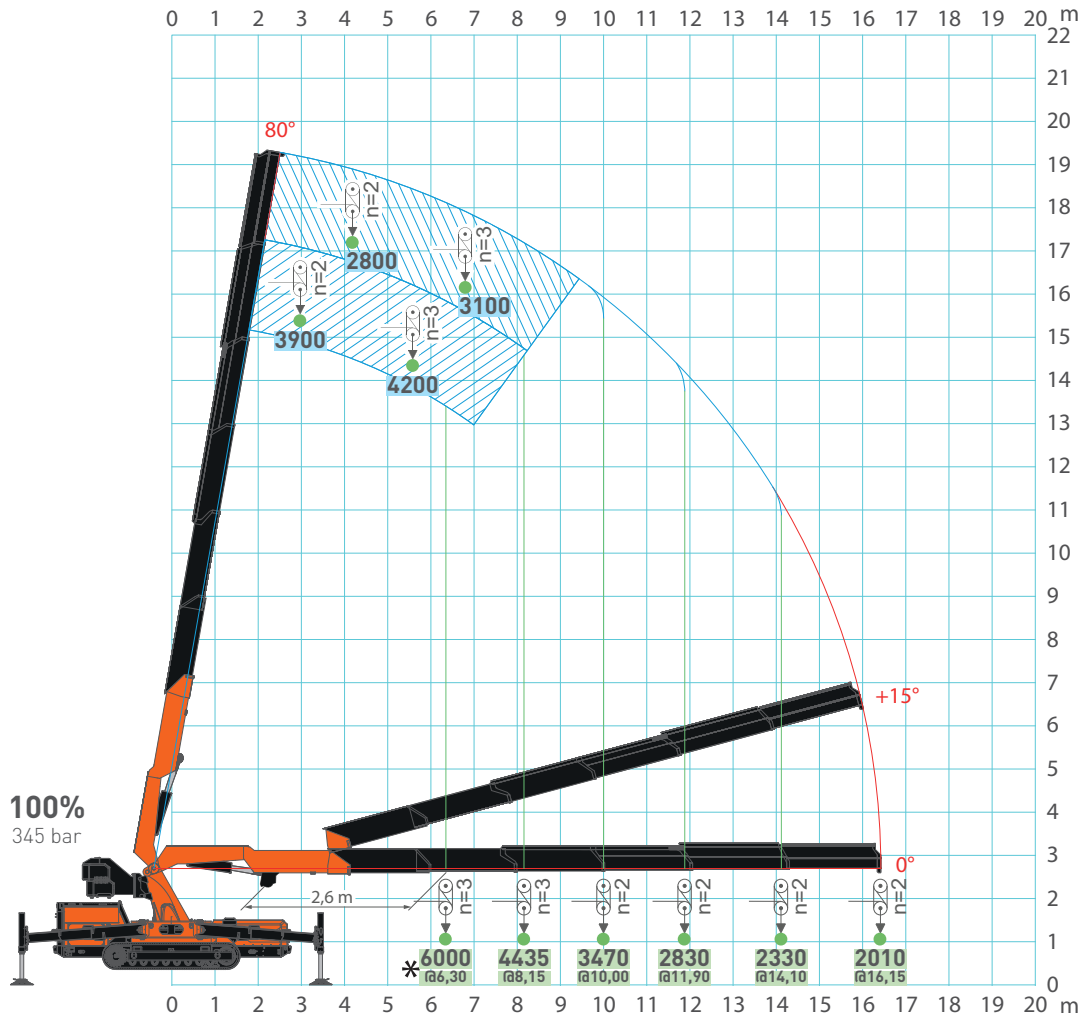

80%
276 bar

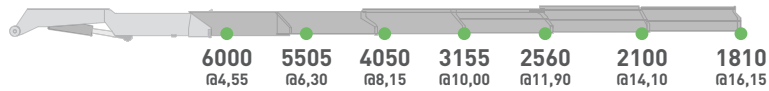

60%
207 bar

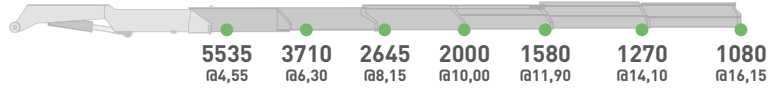

40%
138 bar

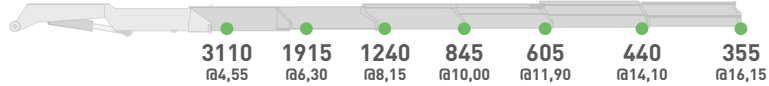

20%
69 bar

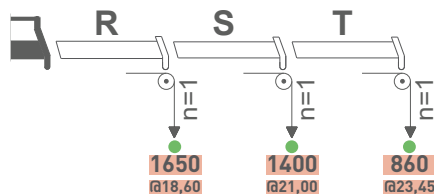

[m] [kg]

JF545 - MAIN BOOM



V30

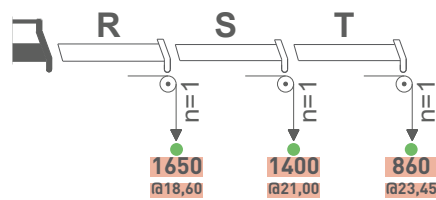
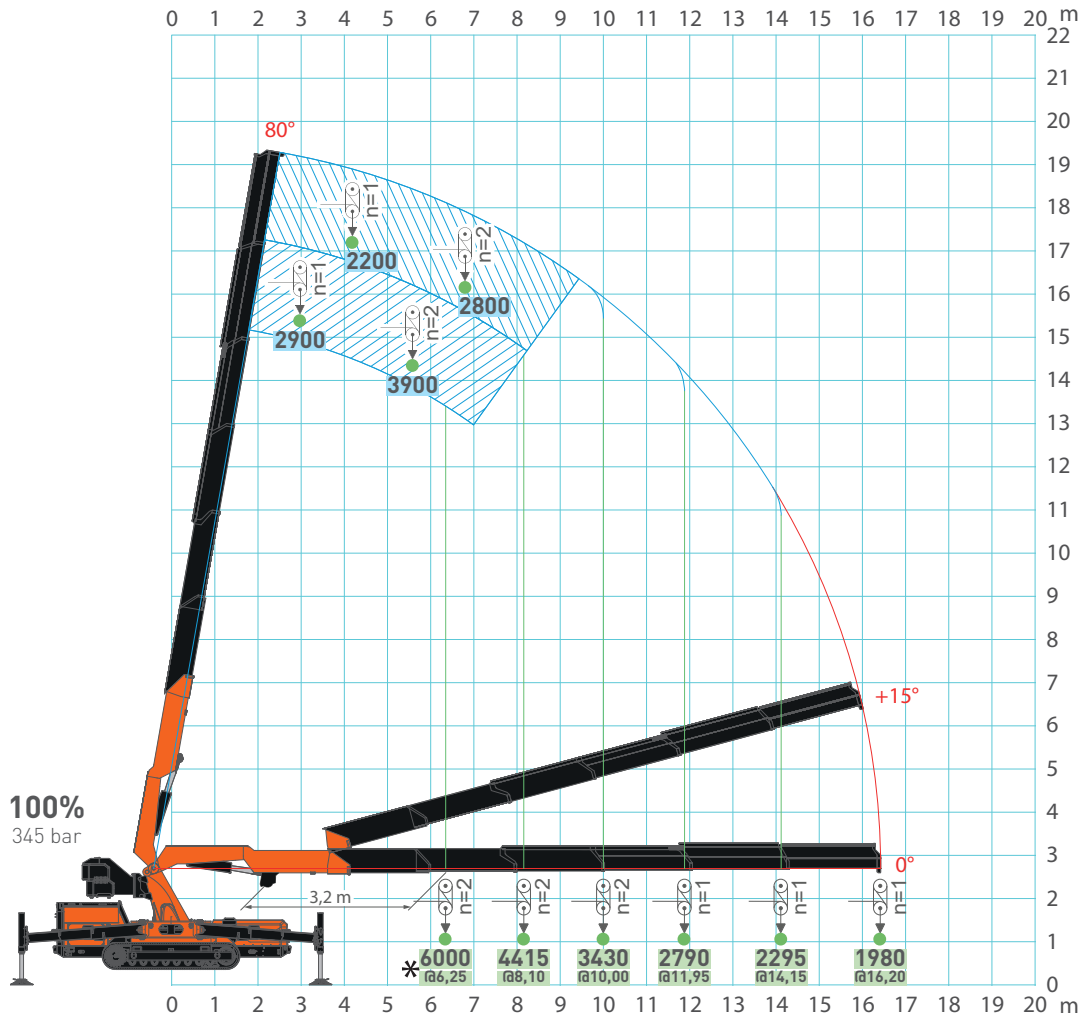

[m] [kg]

JF545 - JIB3000.6HA

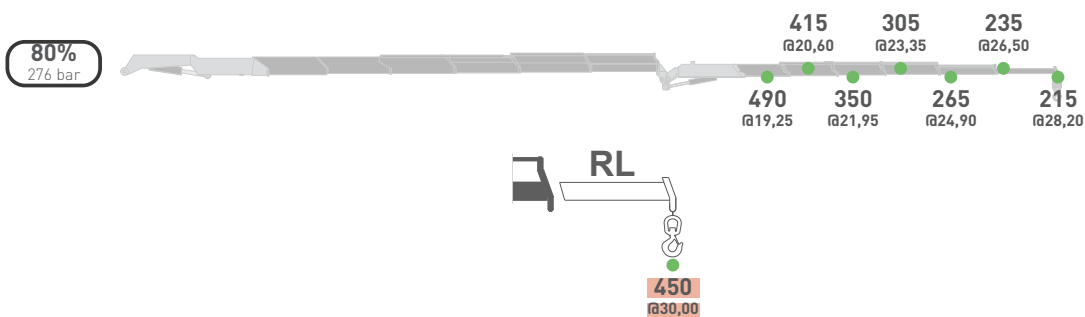
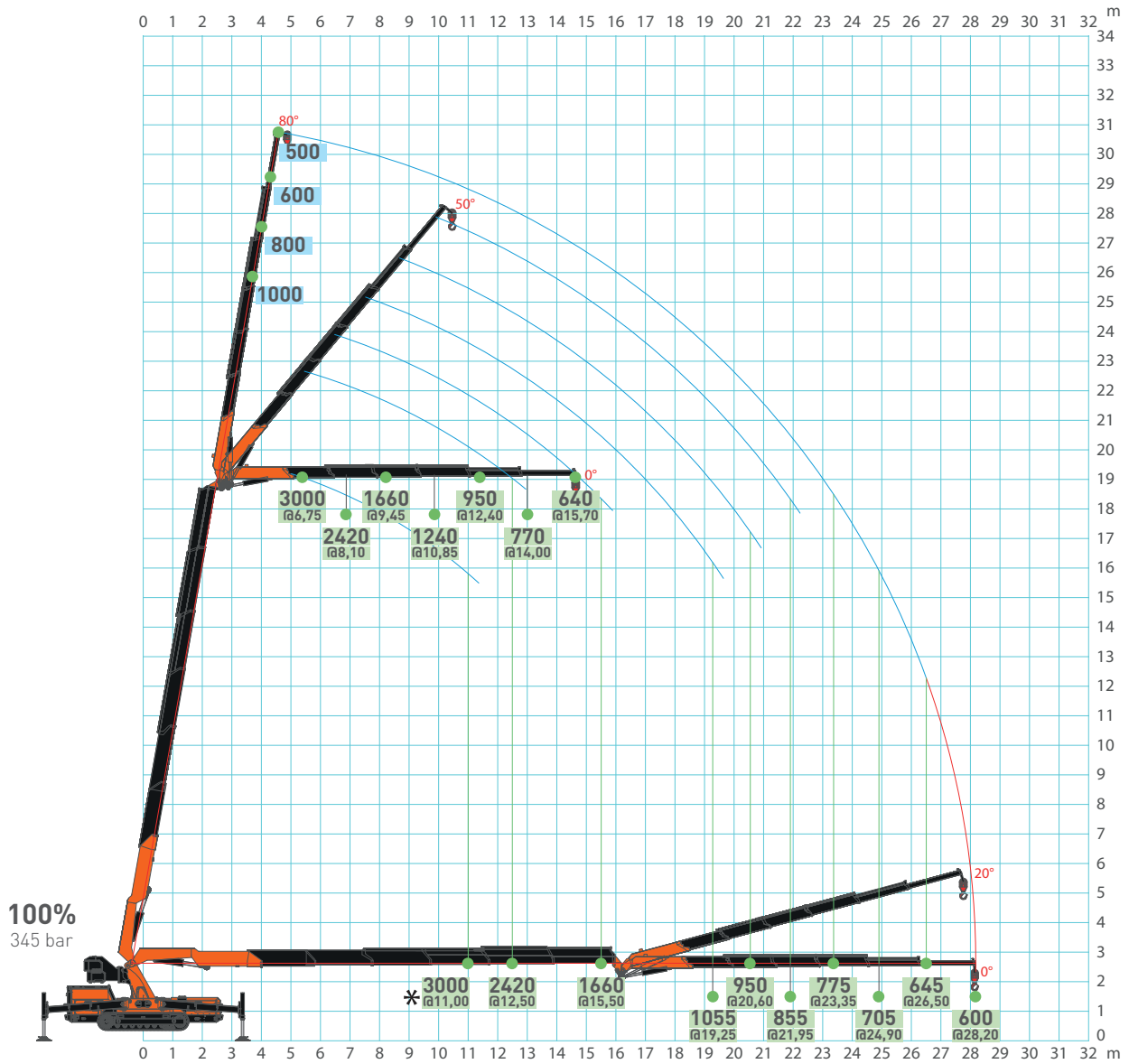

The load chart refers to the crane in deflection condition.

[m] [kg]

JF545 - JIB3000.6HA



V20

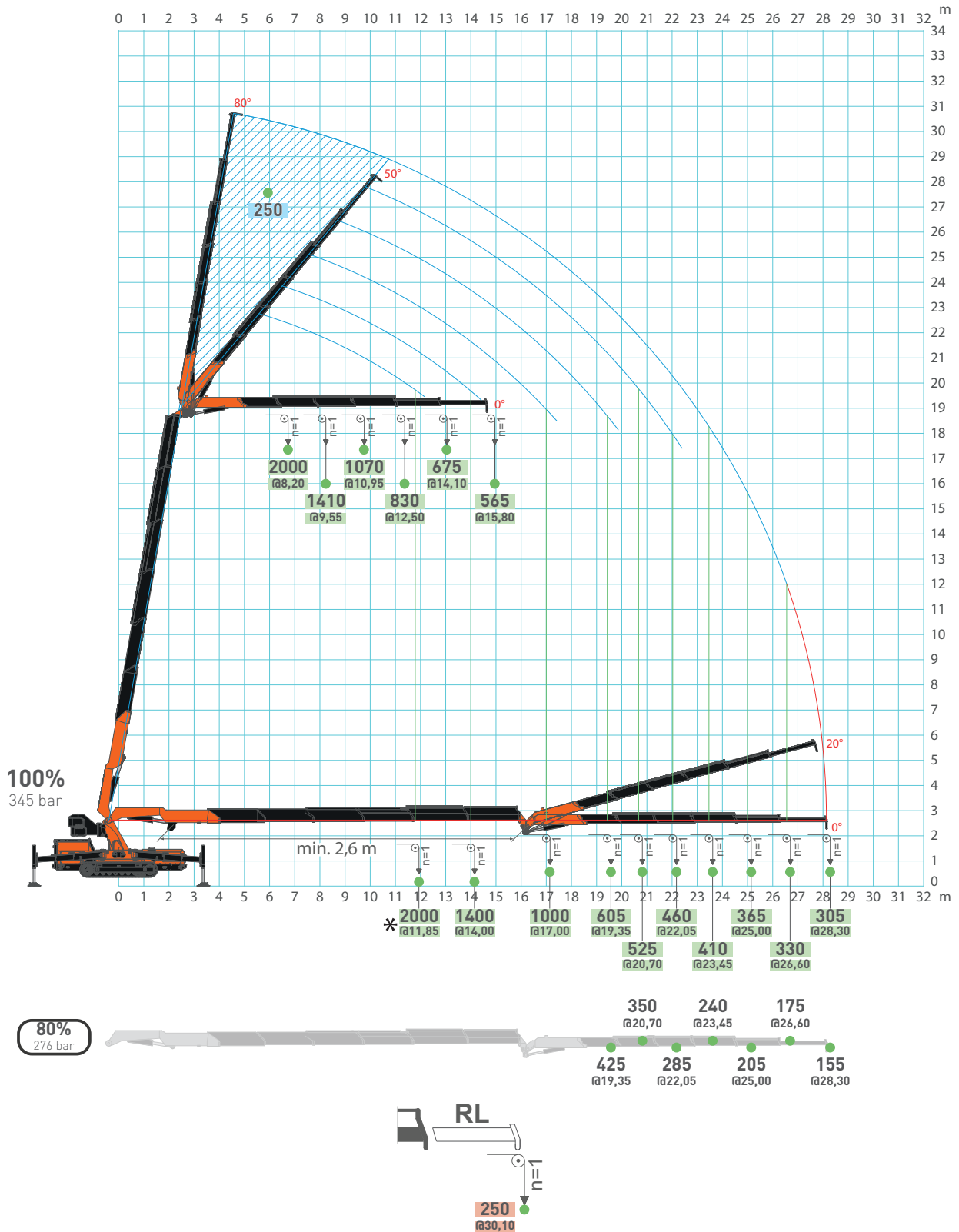

[m] [kg]

The load chart refers to the crane in deflection condition.

JF545 - JIB3000.6HA

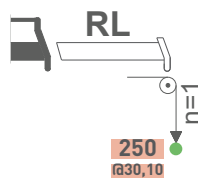
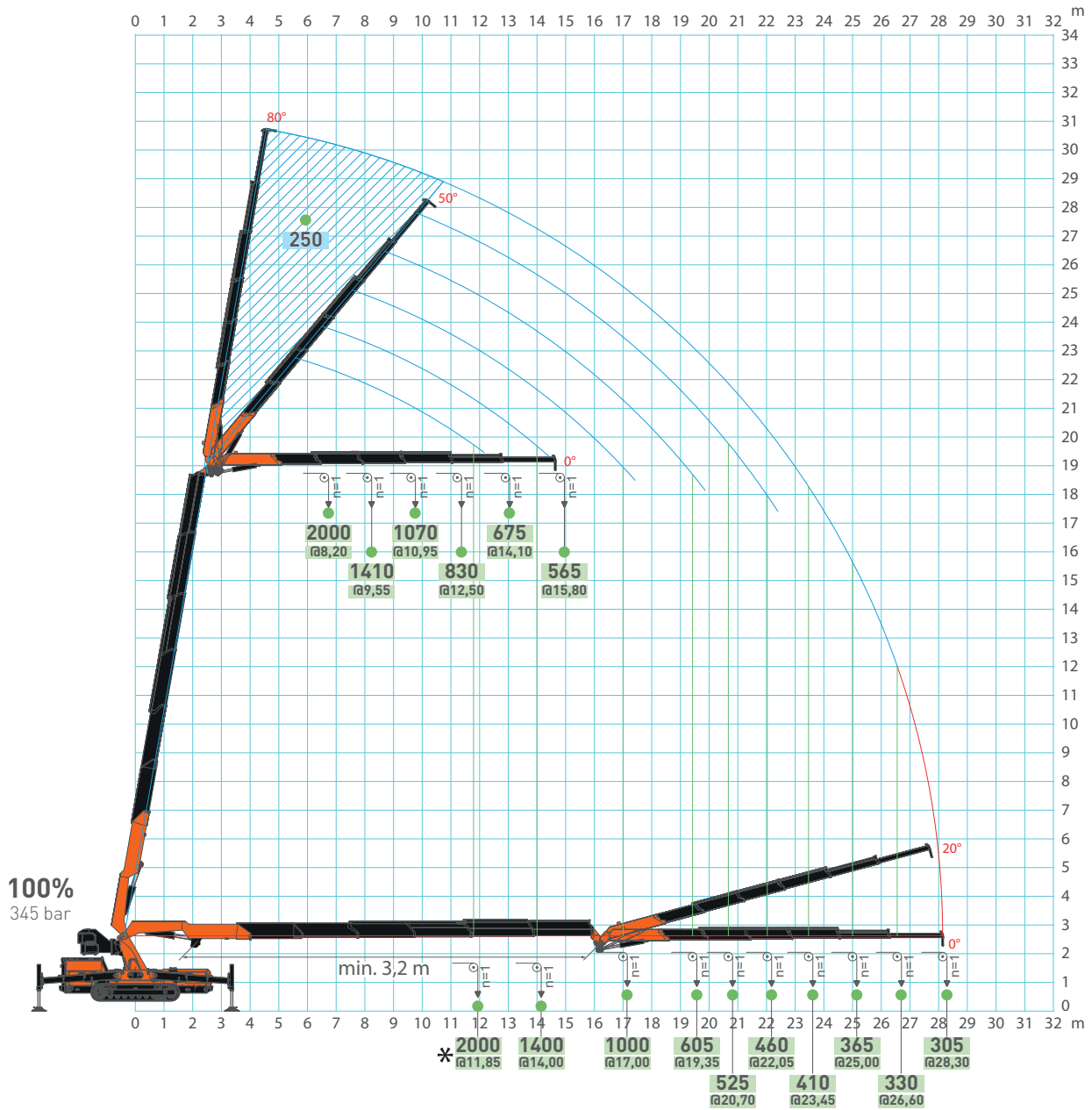

The load chart refers to the crane in deflection condition.

[m] [kg]

JF545 - MWP-2PG.JIB3000.6HA



V20

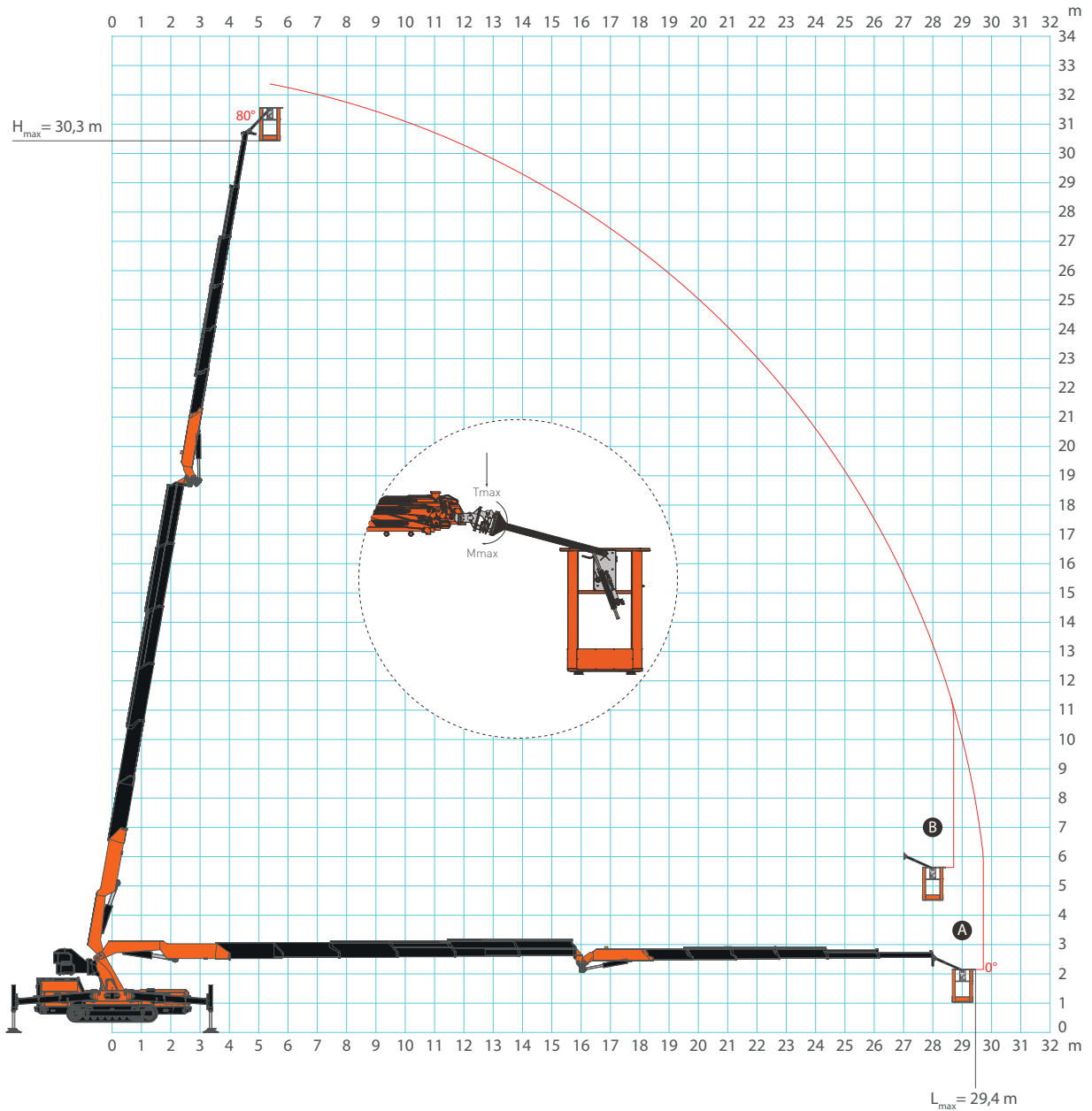

A	PLE	MWP-2PG.JIB3000.6HA	without activation	P_{max}	200 kg
B		MWP-2PG.JIB3000.6HA	with activation	P_{max}	200 kg

*: The load chart refers to the crane in deflection condition.

** : The crane is equipped with LMI. The maximum reachable distance may vary by about 1m.

***: The maximum reachable distance can be reached by extending the JIB first and then extending the boom.

JF545 - MWP-2PGR.JIB3000.6HA



V20

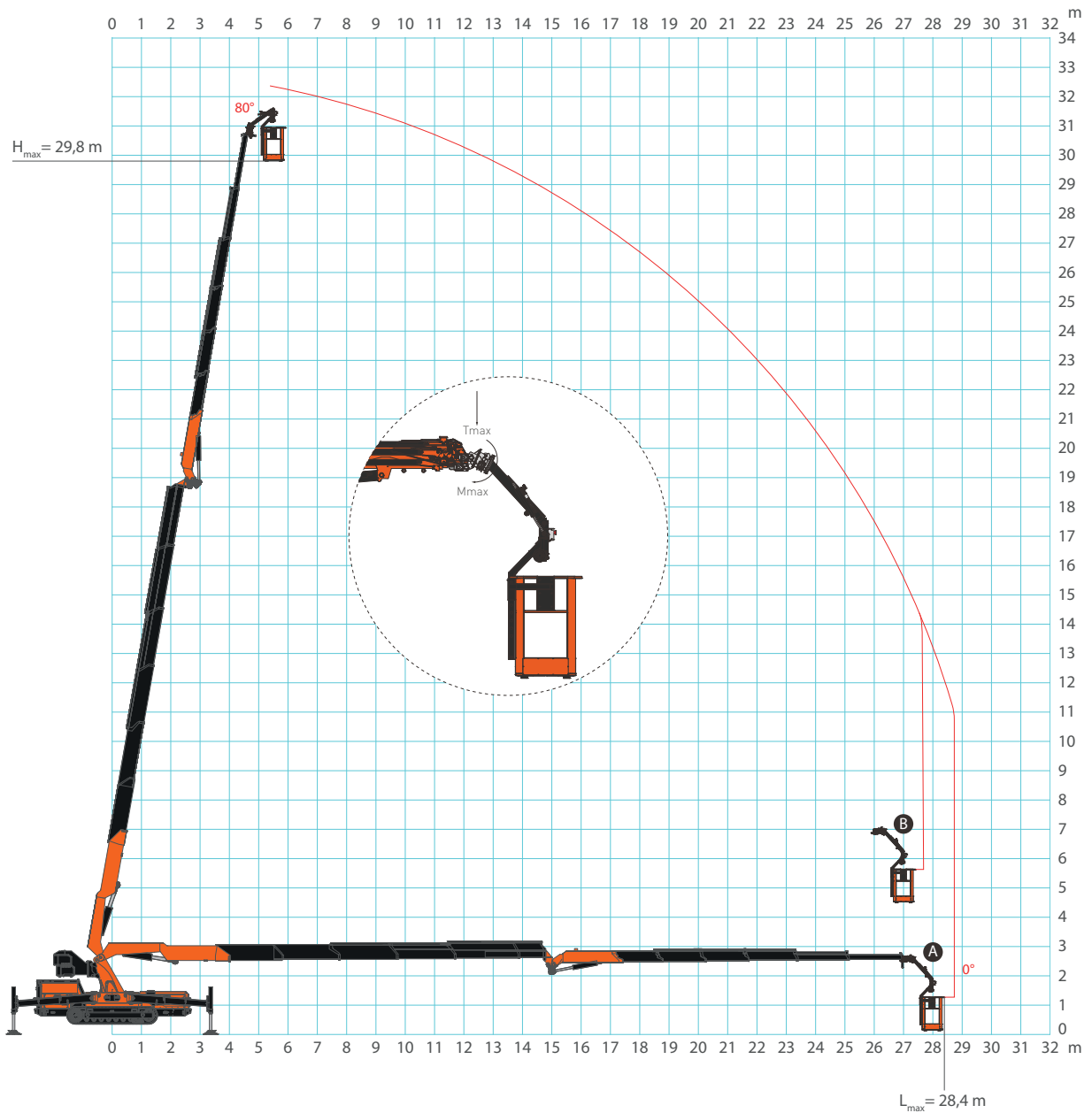

A	PLE	MWP-2PGR.JIB3000.6HA	without activation	P_{max}	200 kg
B		MWP-2PGR.JIB3000.6HA	with activation	P_{max}	200 kg

*: The load chart refers to the crane in deflection condition.

** : The crane is equipped with LMI. The maximum reachable distance may vary by about 1m.

***: The maximum reachable distance can be reached by extending the JIB first and then extending the boom.

Jekko s.r.l

Price List 2023.10 - JF Series

JFS4S

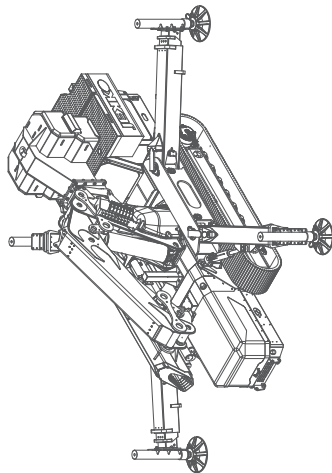

ACCESSORIES JF545 CDH

MAN-BASKET

- MWP-JIB3000.6HA
- MWP-1PG-JIB3000.6HA
- MWP-1PGR-JIB3000.6HA
- MWP-2PG-JIB3000.6HA
- MWP-2PGR-JIB3000.6HA
- MWP-CERT

JIB & ATTACHMENTS

- JIB3000.6HA
- JF-HLS2
- PS-JF545
- PS-JFM-JFX
- MOC-JFS/JFM
- MOC-JFS/JFM-2
- ME1-JIB3000.6HA
- MEH-JIB3000.6HA
- HA-JIB3000.6HA

CRANE OPTIONS

- W2000-JFM
- W3000-JFM-JFX
- JF-HLS1
- CW-JF545
- TB-JFM
- ME1-JF545.6
- MEH-JF545.6
- WA-JFS/JFM
- HA-JFS/JFM

CRAWLER OPTIONS

- PP400.13-JFM
- PP480.13-JFM
- WTP-JF545
- TW-JFM-JFX
- PW10-JF
- HAPW-JFM
- EOC-JF545

WARRANTY EXTENSION

- 2YW-JF545
- 3YW-JF545

COLOR & STICKERS PERSONALIZATION

	CRANE	CHASSIS	COVERS+ TOOL BOXES	OUTRIGGERS' EXTENSIONS
STANDARD:	<input checked="" type="checkbox"/> RAL2004	<input checked="" type="checkbox"/> RAL2004	<input checked="" type="checkbox"/> RAL2004	<input checked="" type="checkbox"/> RAL9005
CUSTOM:	<input type="checkbox"/> PC1	<input type="checkbox"/> PC2	<input type="checkbox"/> PC3	<input type="checkbox"/> PC4

© All rights reserved

ACCESSORIES FEATURES

MEH-JF545.6

MEH-JIB3000.6HA

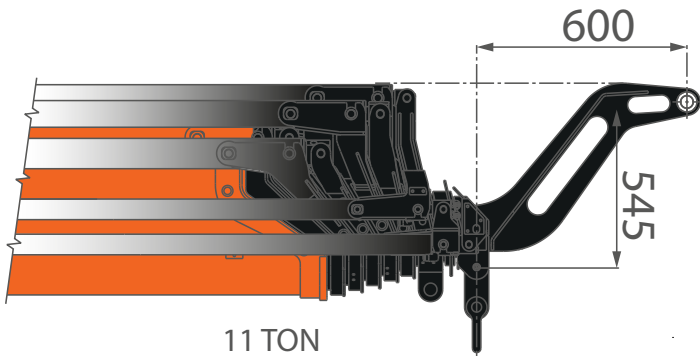

11 TON

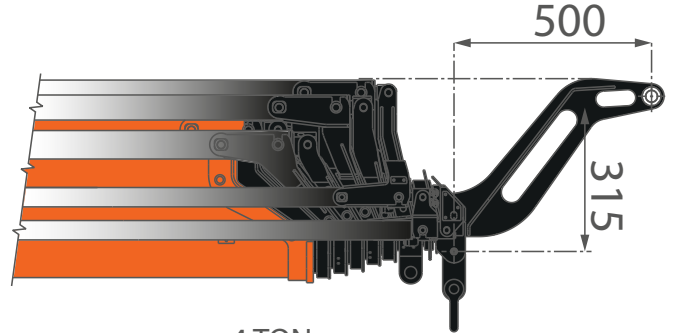

4 TON

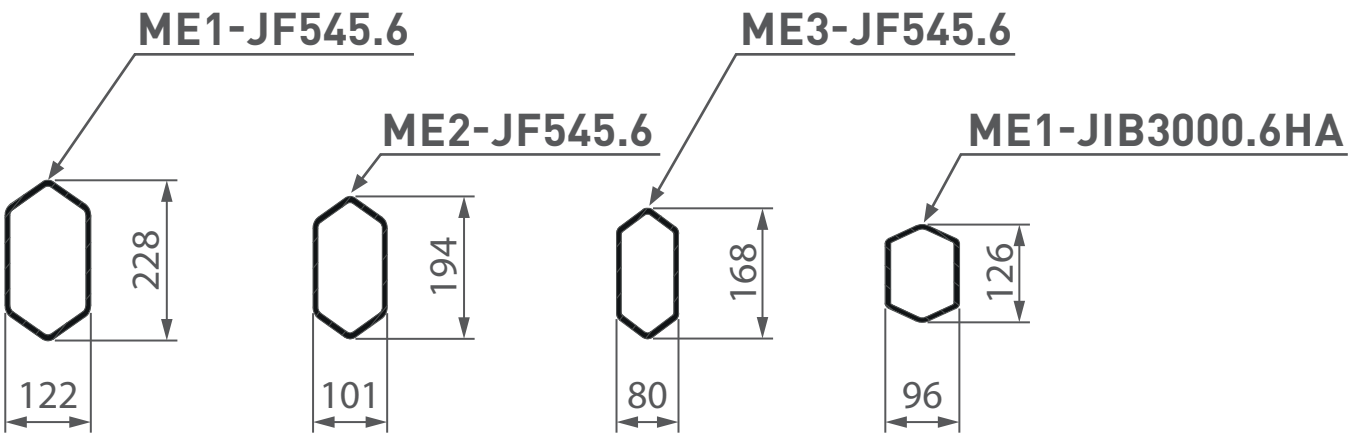
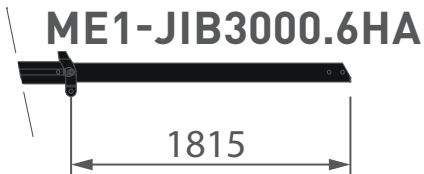
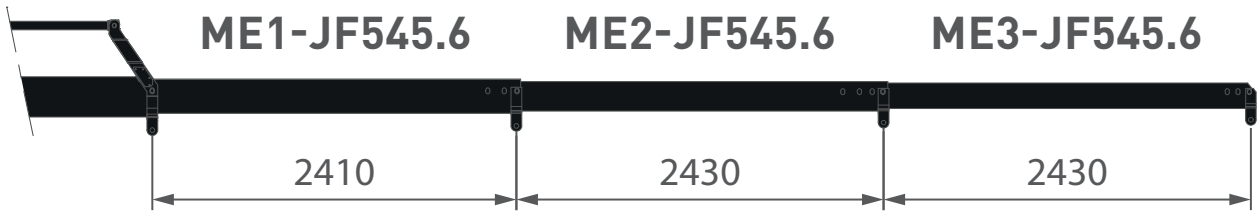

ACCESSORIES FEATURES WTP-JFM

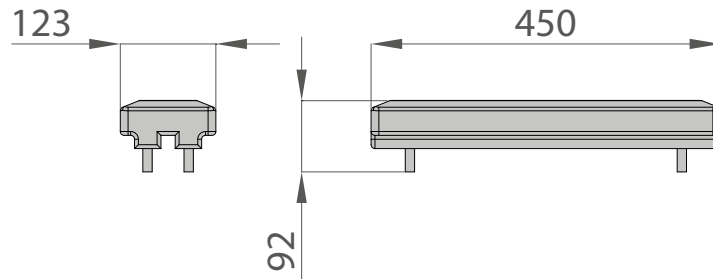

MWP-2PG.JIB3000.6HA

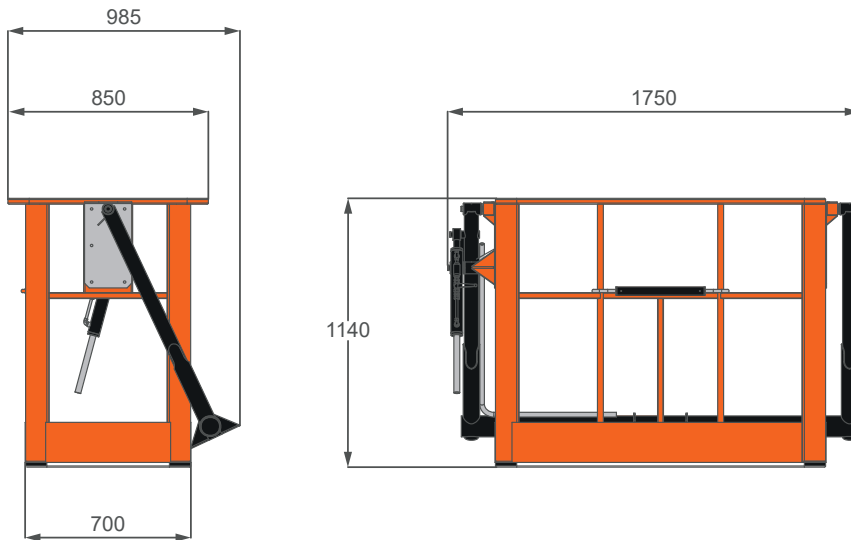

MWP-2PGR.JIB3000.6HA

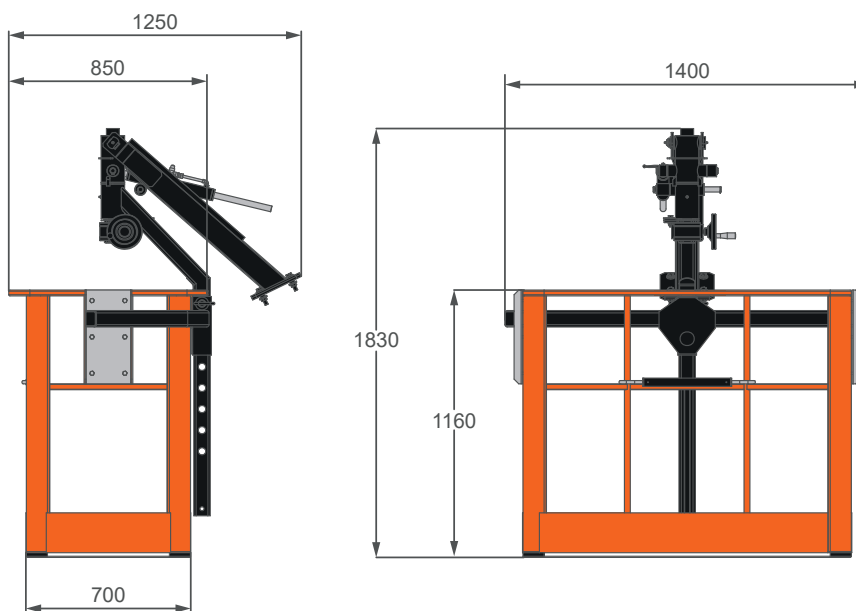

ACCESSORIES FEATURES
JIB3000.6HA

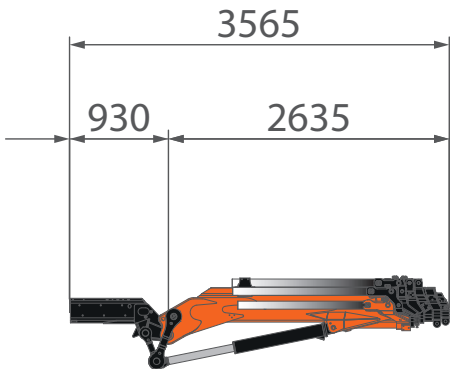

SYMBOLS

	Weight		Diesel Engine		Boom Angle		Outriggers mats
	Crane		Power Pack		Boom Length		Hydraulic oil
	Gradeability		Slewing		Jib		Outrigger Load
	Travel Speed		Electric Engine		Hookblock		Working Temperature
	Track Load		Maximum Capacity		Low marking pads		Main Winch
	Person Lifting Equipment		Hook				

- Load limited by LMI
- Load to be limited by the operator
- Load to be verified and limited by the operator
- * Max. moment

REMARKS REFERRING TO LOAD CHART

- HC1 HD5 S2 lifting class in hook configuration, whereas HC1 HD4 S2 lifting class in winch configuration, according to **EN12999:2020** standards.
- Lifting capacities are given in kg.
- Hookblocks, hooks and eventual manual extensions weight is part of the load and therefore must be deducted from lifting capacities.
- Working radius is measured from the column slewing axis.
- Subject to modification of lifting capacities.



Jekko s.r.l.

Via Campardone, 1 - 31014 Colle Umberto (TV) - Italy
info@jekko.it - www.jekko-cranes.com

29.08.2024 | Rev3.0

SERIAL NUMBER: